



UNINTERRUPTIBLE POWER SUPPLY SYSTEM

MODEL

# 1100B SERIES

OWNER'S / TECHNICAL MANUAL

# Preface

## TABLE OF CONTENTS

LIST OF TABLES.....	II
LIST OF FIGURES .....	III
HOW TO USE THIS MANUAL .....	IV
<b>1 INTRODUCTION .....</b>	<b>1-1</b>
1.1 SAFETY PRECAUTIONS .....	1-2
1.2 GENERAL.....	1-8
1.3 DEFINITIONS .....	1-9
1.4 OPERATION OVERVIEW .....	1-10
1.5 SPECIFICATIONS.....	1-16
<b>2 OPERATOR CONTROLS AND INDICATORS.....</b>	<b>2-1</b>
2.1 EMERGENCY POWER OFF BUTTON .....	2-1
2.2 LIQUID CRYSTAL DISPLAY.....	2-1
2.3 EXTERNAL SIGNAL TERMINAL BLOCK .....	2-7
2.4 EXTERNAL COMMUNICATION CONNECTOR .....	2-12
<b>3 INSTALLATION AND OPERATION.....</b>	<b>3-1</b>
3.1 UPS COMPONENTS .....	3-1
3.2 TRANSPORTATION AND INSTALLATION .....	3-2
3.3 HANDLING .....	3-2
3.4 INSTALLATION PROCEDURE.....	3-4
3.5 PROCEDURE FOR CABLE CONNECTIONS.....	3-8
3.6 OPERATING PROCEDURES .....	3-14
3.7 MAINTENANCE BYPASS SET-UP PROCEDURES .....	3-15
<b>4 RESPONSE TO UPS FAILURE .....</b>	<b>4-1</b>
<b>5 PARTS REPLACEMENT .....</b>	<b>5-1</b>
<b>6 FAULT CODES .....</b>	<b>6-1</b>
6.1 BYPASS MODULE FAULT CODES .....	6-2
6.2 POWER CONVERTER MODULE FAULT CODES .....	6-5
<b>7 WARRANTY &amp; OUT OF WARRANTY SERVICE .....</b>	<b>7-1</b>

---

**LIST OF TABLES**

Table 1.1	UPS Installation Environment.....	1-6
Table 1.2	Rating of AC input circuit breaker .....	1-7
Table 1.3	Power Specifications.....	1-16
<b>Table 1.4</b>	UPS Module Cabinet Information .....	1-16
<b>Table 1.5</b>	Detail of Specifications .....	1-17
<b>Table 1.6</b>	Rating of Contactors and Fuses .....	1-18
<b>Table 3.1</b>	List of UPS component weights .....	3-1
<b>Table 3.2</b>	How to transport and install the system .....	3-2
<b>Table 3.3</b>	List of UPS weights.....	3-4
<b>Table 3.4</b>	Maximum Permitted Fault Current .....	3-6
<b>Table 3.5</b>	Recommended Cable Size and Torque Requirements.....	3-8
<b>Table 3.6</b>	Crimp Type Compression Lug .....	3-9
<b>Table 3.7</b>	Recommended Hardware .....	3-9
<b>Table 6.1</b>	Bypass Module Fault Code List .....	6-2

## LIST OF FIGURES

Figure 1.1	Single Line Diagram - Normal Operation: Load powered by UPS inverter.....	1-10
Figure 1.2	Single Line Diagram - Bypass Operation: Load fed through static bypass line. ...	1-11
Figure 1.3	Single Line Diagram - Battery Operation.....	1-12
Figure 1.4	UPS Parts Location.....	1-13
Figure 1.5	UPS Parts Location (Bypass Module).....	1-14
Figure 1.6	External I/F Module.....	1-14
Figure 2.1	Operation/Display Panel (Front panel).....	2-1
Figure 2.2	Main screen.....	2-2
Figure 2.3	Startup guidance.....	2-2
Figure 2.4	Shutdown guidance.....	2-2
Figure 2.5	Screen select menu.....	2-2
Figure 2.6	Input values.....	2-3
Figure 2.7	Output values.....	2-3
Figure 2.8	Measurement during.....	2-3
Figure 2.9	Each Power Converter Module.....	2-3
Figure 2.10	Status log.....	2-3
Figure 2.11	Battery log.....	2-3
Figure 2.12	Power Converter Failure log.....	2-3
Figure 2.13	Power C onverter Failure log.....	2-3
Figure 2.14	Remote/Local operation select.....	2-4
Figure 2.15	Date & Time adjustment.....	2-4
Figure 2.16	Main screen.....	2-4
Figure 2.17	Measurement screen.....	2-4
Figure 2.18	Main screen (Fault indication).....	2-5
Figure 2.19	Message screen.....	2-5
Figure 2.20	MENU Tree.....	2-6
Figure 2.21	External Signal Terminal Block (NEC Class2).....	2-8
Figure 2.22	External Signal Terminal Block (NEC Class2).....	2-9
Figure 2.23	Control Wiring for External Contacts.....	2-10
Figure 2.24	Remote "Start" Contact Connections.....	2-11
Figure 2.25	External communication connector (NEC Class2).....	2-12
Figure 3.1	UPS Components.....	3-1
Figure 3.2	Handling.....	3-3
Figure 3.3	Clearance for ventilation and maintenance.....	3-4
Figure 3.4	Rear Clearance for ventilation and maintenance for 10kVA and 20kVA.....	3-5
Figure 3.5	Install Power Converter Module and Bypass Module.....	3-7
Figure 3.6	Hardware configuration.....	3-9
Figure 3.7	UPS Terminal Designation.....	3-10
Figure 3.8	Cable connection for dual input.....	3-10
Figure 3.9	Cable connection for single input.....	3-10
Figure 3.10	Input/Output Power Terminals.....	3-11
Figure 3.11	In case of Bottom Cable Entry.....	3-12
Figure 3.12	In case of Bottom Cable Entry.....	3-13

## HOW TO USE THIS MANUAL

This manual is designed for ease of use, giving the user easy and quick reference to information.

This manual uses notice icons to draw attention to the user important about information regarding the safe operation and installation of the UPS. The notice icons used in this manual are explained below, and should be taken into account and adhered to whenever they appear in the text of this manual.



**WARNING**

**WARNING:** A warning symbol shows potentially hazardous situation or condition which could result in personal injury or death, if not avoided.



**CAUTION**

**CAUTION:** A caution symbol shows potentially hazardous situation or condition which could result in personal injury or equipment damage, if not avoided.



**NOTE**

**NOTE:** A Note symbol shows the information the user or the service personnel should observe during the UPS operation or service work.



**INHIBIT**

**INHIBIT:** A inhibit symbol shows the act the user or the service personnel should NEVER perform during the UPS installation, operation or service work.

**Safety Recommendations:** If any problems are encountered while following this manual, Mitsubishi Electric field service group assistance and correspondence is recommended.

## 1 INTRODUCTION

Your Mitsubishi Uninterruptible Power Supply (UPS) is designed to provide many years of reliable power supply and protection from power failure, brown-outs, line noise and voltage transients. To ensure optimum performance of the equipment, follow the manufacturer's instructions accordingly. This manual contains descriptions for the installation and operation procedures of the UPS. Please read this manual carefully and retain it for future reference.



### IMPORTANT SAFETY INSTRUCTIONS SAVE THESE INSTRUCTIONS

This manual contains important instructions for the 1100 Series Uninterruptible Power Supply Systems that should be adhered to during installation, operation and maintenance of the UPS and batteries.



### WARNING 1

Lethal voltages exist within the equipment during operation.  
Observe all warning and cautions in this manual.  
Failure to comply may result in serious injury or death.  
Obtain a qualified service for this equipment as per instructions.



### WARNING 2

In no event will MITSUBISHI be responsible or liable for either indirect or consequential damage or injury that may come from the use of this equipment.  
Any modifications without authorization by MITSUBISHI could result in personal injuries, death or destruction of the UPS.

## 1.1 SAFETY PRECAUTIONS

The safety precautions are categorized as **DANGER** and **CAUTION** in this manual.

**DANGER** : A dangerous situation may occur if improperly handled, leading to severe or fatal injuries.

**CAUTION** : A dangerous situation may occur if improperly handled, leading to minor serious injuries.

Note that some items described as **CAUTION** may lead to severe results depending on the situation. Nonetheless, important information outlined in this section must be observed at all times.

### DANGER

- Do not dispose the batteries in fire as they may explode.
- Do not open or break the batteries. Released electrolyte is toxic and harmful to the eyes and skin.
- A battery can present a risk of electrical shock and high short circuit current. Observe the following minimum Safety Precautions when working on the batteries.
  - 1) Remove watches, rings or other metal objects.
  - 2) Use tools with insulated handles to prevent inadvertent shorts.
  - 3) Wear rubber gloves and boots.
  - 4) Do not lay tools or metal parts on top of the batteries.
  - 5) Disconnect charging source prior to connecting or disconnecting battery terminals.
  - 6) Determine if the battery is inadvertently grounded. If so, remove source of ground. Contact with any part of a grounded battery can result in electrical shock. The likelihood of such shock will be reduced if grounds are removed during installation and maintenance.



## CAUTION

### PRECAUTIONS FOR INSTALLATION

- **Do not block the intake/exhaust ports.**
  - If the intake/exhaust ports are blocked, the internal temperature of the UPS will rise and could lead to fires from battery electrolyte leakage, fire ignition or part deterioration.
  - Exhaust from the rear of the equipment can be released at elevated temperatures. If any other equipment is expected to be installed in area behind this one, put adequate distance between the two.
- **Follow the UPS instruction manual carefully when installing the unit.**
  - Improper installation could lead to injury such as the UPS falling over, etc.

### PRECAUTIONS FOR WIRING

- **The power supply for this unit must be three phase rated in accordance with the equipment data plate. It must be suitably grounded.**
  - Failure to ground the unit could lead to electrical shocks.

### PRECAUTIONS FOR USE

- **If a unit fault, abnormal odor or noise occurs, turn off the UPS input switch.**
  - Failure to do so could lead to fires.
- **Do not insert blunt objects or fingers, etc., in the fan.**
  - Failure to observe this could lead to injuries.
- **Do not insert blunt objects or fingers, etc., into the unit's input/output section.**
  - Failure to observe this could lead to electrical shocks.
- **Ventilate the UPS surroundings.**
  - Failure to do so could lead to container rupture or to explosions from the gas generated from the battery system.
- **Prohibit smoking and the use of fire around the unit.**
  - Failure to do so could lead to injuries, damage or fires from explosions.
- **Do not place containers that have water or any liquids on the UPS.**
  - If the container tips over and the water or liquids spills, this could lead to electrical shocks and to fires in the UPS.
- **Do not sit on, step on or lean on the UPS.**
  - Failure to observe this could lead to injuries if the UPS tips over.

## CAUTION

### PRECAUTIONS FOR MAINTENANCE AND INSPECTION

- **The inside of the UPS must be inspected or repaired only by qualified personnel.**
  - Failure to observe this could lead to electrical shocks, injuries, burns, smoke generation or fires.
- **Periodically replace the battery.**
  - Batteries that have exceeded the replacement life could lead to fires from electrolyte leakage or fire ignition.
- **Contact the dealer or service company for unit maintenance and repairs, and for the replacement of defective parts.**
  - Opening the cover could lead to electrical shocks or burns.
  - Do not touch high temperature parts such as radiation fins. Those high temperature parts may cause burn injuries even after power-off

### PRECAUTIONS FOR BATTERY

- **If the battery ignites, do not use water to extinguish the fire. Instead, use a powder (ABC) fire extinguisher.**
  - Use of water could cause the fire to grow.
- **Toxic diluted sulfuric acid in the battery.**
  - If electrolyte leaks from the unit, avoid contact with the skin or clothes.
  - If electrolyte makes contact with the skin or clothes, wash it off thoroughly with clean water.
  - If electrolyte makes contact with the eyes, rinse immediately and thoroughly with clean water, and then see a doctor. The presence of sulfuric acid in the eyes could lead to blindness, and adherence to skin could lead to burns.

### PRECAUTIONS FOR OPERATION

- **Operating method.**
  - To obtain stable operation, it is advisable that the UPS is operated on a continuous basis. Even if you start or stop the equipment at daily intervals, keep the converter running and start or stop the inverter alone.
- **Extended shutdown.**
  - If the UPS is placed into stopped state for durations of the order of several months, operate the converter for a day or two at monthly intervals. (Charge the batteries. Left uncharged for a long time, they can run down due to self-discharge.)
- **Do not touch live parts even after equipment is shut down.**
  - Because the converter is kept operational after the stoppage of the inverter, voltage remains applied to the internals of the equipment. Also, it takes about 5 minutes after the stoppage of the converter for voltage across the DC circuit to dissipate to a safe level in the range of 20V. Avoid contacting the live part of the equipment and the supply side of the breaker because they stay energized in this way even after equipment shutdown steps are performed.

## CAUTION

### OTHER PRECAUTIONS

• **Never use or store the unit in the following types of environment:**

- a) A location having a low or high temperature or high humidity deviated from the ambient environment conditions described in the brochure or instruction manual.
- b) A location submerged in water or where the unit could become wet from dripping water.
- c) At an altitude higher than 7400 feet (2220 meters).
- d) In direct sunlight.
- e) Where organic solvents (gasoline, paint thinner, etc.) are stored.
- f) A location that is dusty.
- g) A location containing combustible gas, corrosive gas, salt or oil mist.
- h) A location subject to vibration or impacts.
- i) A location near devices that generate sparks or near heating elements.

## APPLICATION

**If the UPS System is to be applied to support equipment that could affect human safety, the following steps must be adhered to:**

1. Consult with Mitsubishi Electric Power Products Inc. UPS Division.
2. Special consideration of the overall back up power system configuration is required so that the Mitsubishi UPS System is not the sole support required for operation, maintenance and management of power availability. Other available power sources; for example utility, emergency power generation or other systems shall also support power availability.

**Definition of equipment that could affect human safety:**

- Life Support Systems: a system whose failure to perform can be expected to result in bodily injury or death.
- Essential Public Systems: a system whose failure to perform can be expected to result in bodily injury or death and/or property damage.



**WARNING 3**

**The UPS is to be installed in a controlled environment.  
Improper storage and installation environment may deteriorate insulation,  
shorten component life and cause malfunctions.  
Keep the installation environment per standard described as follows:**

**Table 1.1 UPS Installation Environment**

No.	Item	Environment standard	
1	Installation location	Indoors	
2	Ambient temperature	Minimum temperature: 32°F(0°C), Maximum temperature: 104°F(40°C) The average temperature over any 24-hour period must be in the range 41° F (5°C) to 95°F(35°C).	
3	Relative humidity	The relative humidity must be held between 5 and 95%. There must be no condensation due to temperature changes.	
4	Altitude	This equipment must not be applied at altitude that exceeds 2220m (7400ft) above sea level.	
5	Dust	Dust in the room where the UPS is installed must not exceed normal atmospheric dust levels. In particular, that dust should not include iron particles, oils or fats, or organic materials such as silicone.	
6	Inflammable gas	There should be no inflammable/explosive gas.	
		Hydrogen sulfide (H <sub>2</sub> S)	No more than 0.0001 PPM
		Sulfurous acid gas (SO <sub>2</sub> )	No more than 0.05 PPM
		Chlorine gas (Cl <sub>2</sub> )	No more than 0.002 PPM
		Ammonia gas (NH <sub>3</sub> )	No more than 0.1 PPM
		Nitrous acid gas (NO <sub>2</sub> )	No more than 0.02 PPM
		Nitrous oxides (NO <sub>x</sub> )	No more than 0.02 PPM
		Ozone (O <sub>3</sub> )	No more than 0.002 PPM
Hydrochloric acid mist (HCl)	No more than 0.1 mg/m <sup>3</sup>		

**WARNING 4**

This UPS does not include an AC input circuit breaker (MCCB) to protect the bypass and main input circuit. The AC input circuit breaker (MCCB) is to be field supplied and installed. Recommended circuit breaker (MCCB)'s specifications are as follows:

**Table 1.2 Rating of AC input circuit breaker**

Capacity (kVA)	Input Voltage (VAC)	Maximum AC Input Rating (AAC)	Recommended Breaker (A)
10	208	30	40
20	208	60	80
30	208	90	110
40	208	120	150
50	208	150	200
60	208	180	220
70	208	210	260
80	208	240	300

AC input and AC output over current protection and disconnect devices shall be field supplied and installed. DC output over current protection and disconnect device shall be field supplied and installed.

## **1.2 GENERAL**

Your Mitsubishi 1100B Series UPS is designed to provide continuous and clean electrical power to a critical load. In the event of an input power failure, the UPS will supply power to the critical load for the specified battery time.

If the input power is not restored promptly, back up power from the UPS battery permits the orderly shutdown of equipment supported by the UPS. The UPS is simple to start up, operate and maintain.

The 1100B Series UPS is configurable in eight (8) kVA capacities: 10, 20, 30, 40, 50, 60, 70 and 80kVA. Specifications for each capacity appear in Section 1.5. The principles of operation described herein are applicable to all configurations.

This manual provides an overview of the 1100B Series UPS components and their functions. The appearance and purpose of operator controls and indicators are described with procedures for operation, start-up, shutdown and basic maintenance included.

### 1.3 DEFINITIONS

**UNINTERRUPTIBLE POWER SUPPLY SYSTEM (UPS)** - All components within the UPS Module Cabinet in combination with the batteries (external and/or internal) which function as a system to provide continuous, conditioned AC power to a load. This is sometimes referred to as the "System".

**UPS MODULE CABINET** - The enclosure which contains Power Converter Module, Bypass Module, Batteries, and operator controls required to provide specified AC power to a load.

**POWER CONVERTER MODULE** - The Converter / Charger and Inverter assemblies which, under the direction of the Bypass Module and operator controls, provide specified AC power to a load.

**BYPASS MODULE** – Assembly which contains Static Transfer Switch, the internal bypass line, and the internal control system. With operator controls, gives directions required to the Power Converter Module to provide specified AC power to a load.

**CONVERTER / CHARGER** - The UPS components which contain the equipment and controls necessary to convert input AC power to regulated DC power required for battery charging and for supplying power to the Inverter.

**INVERTER** - The UPS components which contain the equipment and controls necessary to convert DC power from the Converter / Charger, or the battery, to AC power required by the critical load.

**STATIC TRANSFER SWITCH** - The device which connects the critical load to the bypass line when the UPS module cannot supply conditioned power.

**BYPASS LINE** - The line which conducts electricity directly from the input power source to the critical load during Maintenance or whenever the UPS is not completely operational.

**INPUT POWER** - Power provided by the electrical utility company, or auxiliary generator, which is connected to the UPS for supplying the critical load.

**BATTERY** - Rechargeable battery strings which supply DC power to the inverter to maintain continuous AC power to the load during AC input power failure conditions.

**1.4 OPERATION OVERVIEW**

The UPS provides two power paths between the utility source and the critical load. Figure 1.1 shows the path for normal operation, with the load powered from the inverter. Figure 1.2 shows the path for bypass operation, with the load supplied through the static bypass line.

**A) Normal operation:** Load power supplied by UPS inverter.

**Figure 1.1** Single Line Diagram - Normal Operation: Load powered by UPS inverter

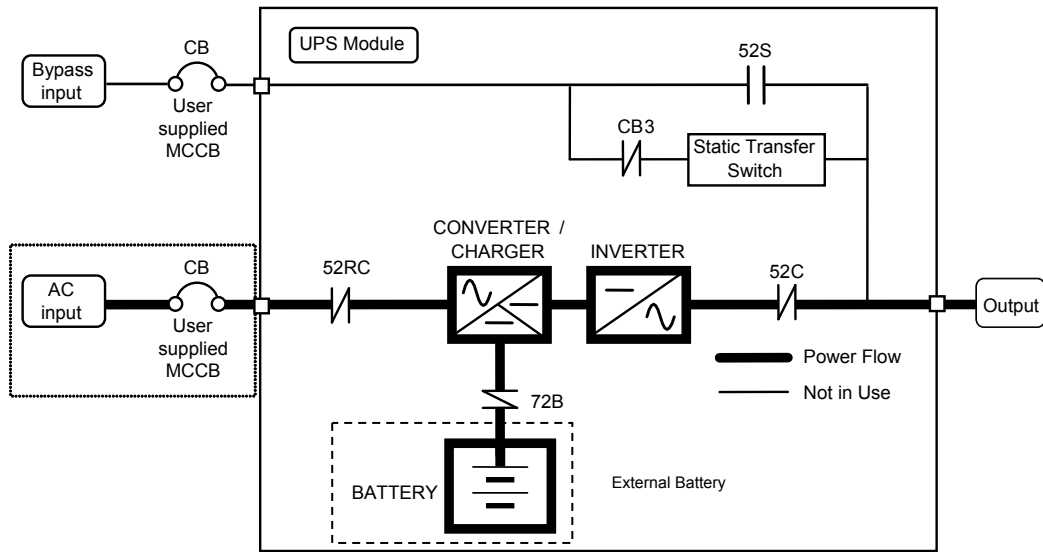

During normal operation, the path through the UPS inverters is used to power the load.

Referring to Figure 1.1: Input AC power is converted to DC by the Converter. DC power is utilized to charge the UPS battery and to provide power to the Inverter. The Inverter converts the DC power to clean AC power to supply the critical load.

The conversion - inversion process eliminates any voltage transients or fluctuations existing in the input power before it reaches the critical load.



**WARNING :** The Bypass input circuit breaker (MCCB) for protection of the UPS and cables are field supplied and field installed. (See WARNING 4 on page 1-7).



**B) Bypass Operation:** Load power supplied through UPS internal static bypass line.

**Figure 1.2** Single Line Diagram - Bypass Operation: Load fed through static bypass line.

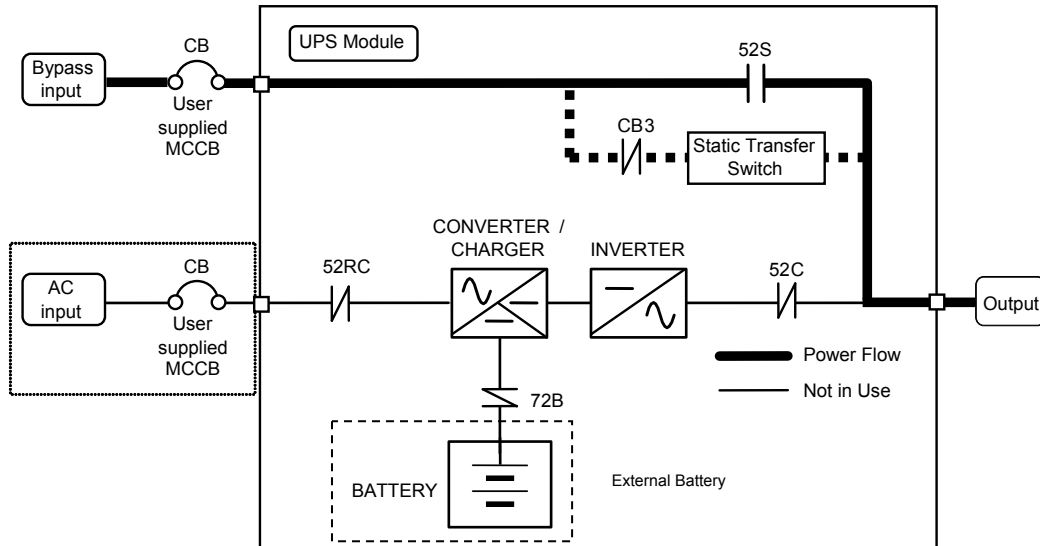

Referring to Figure 1.2: The Internal bypass line is a hard-wired line through 52S which supplies the critical load with unconditioned bypass input power. Upon switching to the internal bypass line, the static transfer switch line through CB3 (herein after STS contactor CB3) supplies the power immediately, and then the internal bypass line through 52S supplies the power. In the event of a switching to the bypass line, the power to the critical load will be uninterrupted. The purpose of this internal bypass line is to route power to the critical load while the UPS module is de-energized (converter and inverter), and during start-up before the system is fully operational.

In the event of a load overcurrent, the UPS transfers to bypass without interruption to the critical load.

The internal control system determines the operation of the two paths, with the load powered from the inverter being the normal operation.

**C) Battery operation: Load power supplied by UPS battery.**

**Figure 1.3** Single Line Diagram - Battery Operation

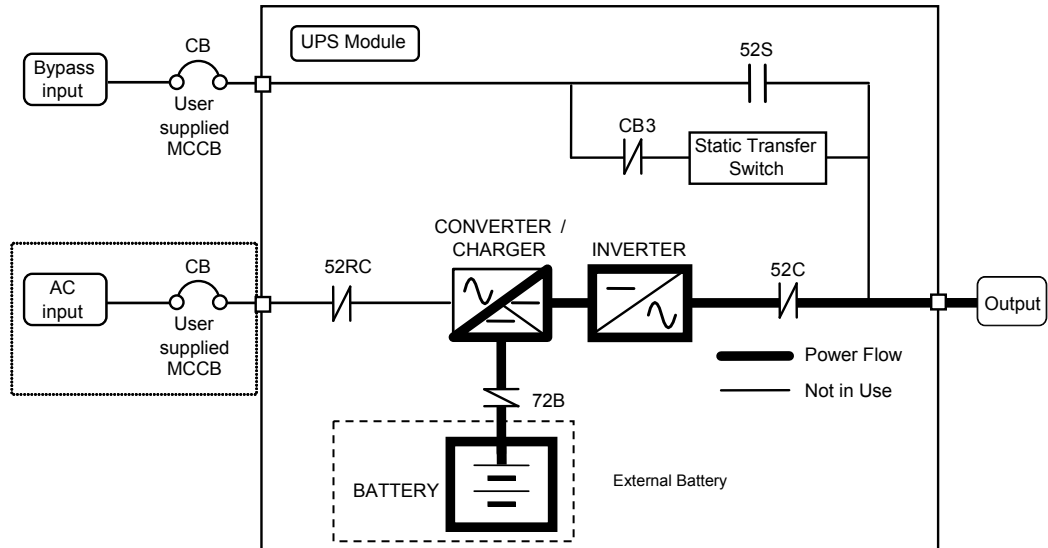

Referring to Figure 1.3: In the event of AC input source failure or interruption, the UPS converter will de-energize and the UPS battery will immediately discharge and supply DC power to the inverter to maintain continuous AC power to the load. This operation will continue until:

- a) The battery capacity expires and the inverter turns off, or
- b) Input power is restored after which the converter will power the inverter and critical load and simultaneously recharge the batteries.

A fully charged battery will provide power for the specified time at the rated load, or longer, at a reduced load.

When power is restored after a low battery shutdown, the UPS converter automatically restarts operation, the charger recharges the batteries and the Inverter is automatically restarted without operator intervention. Load is automatically assumed by the inverter without operator intervention.

**Figure 1.4** UPS Parts Location

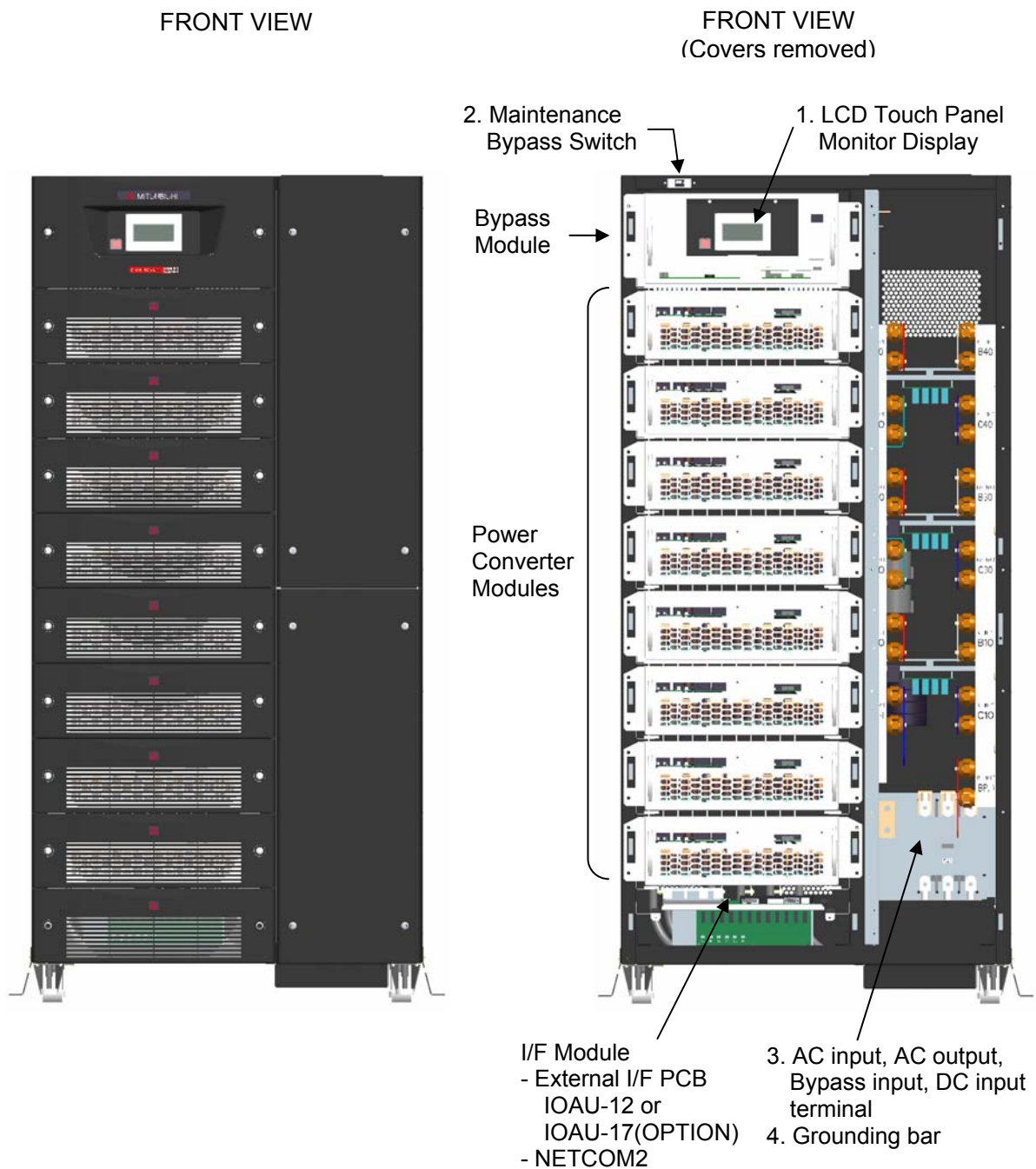

\* Items 3 and 4 (AC input, AC output, DC input terminal, and Grounding Bar) is not shown in Figure 1.4. (Refer to Figure 3.9)

**Figure 1.5 UPS Parts Location (Bypass Module)**

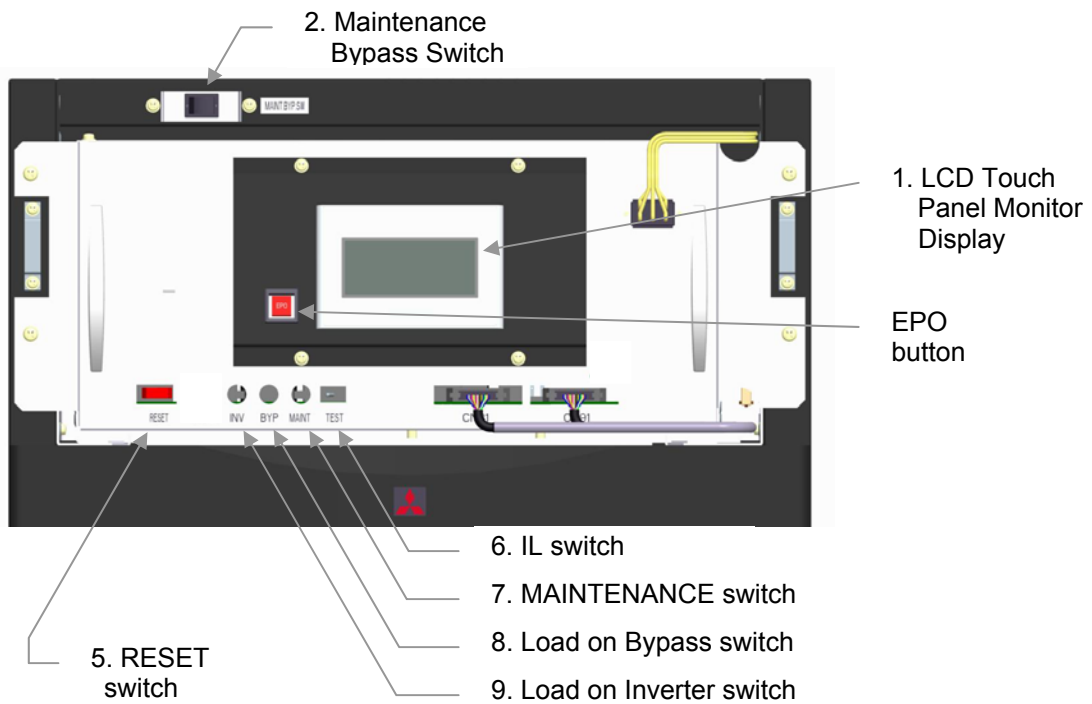

**Figure 1.6 External I/F Module**

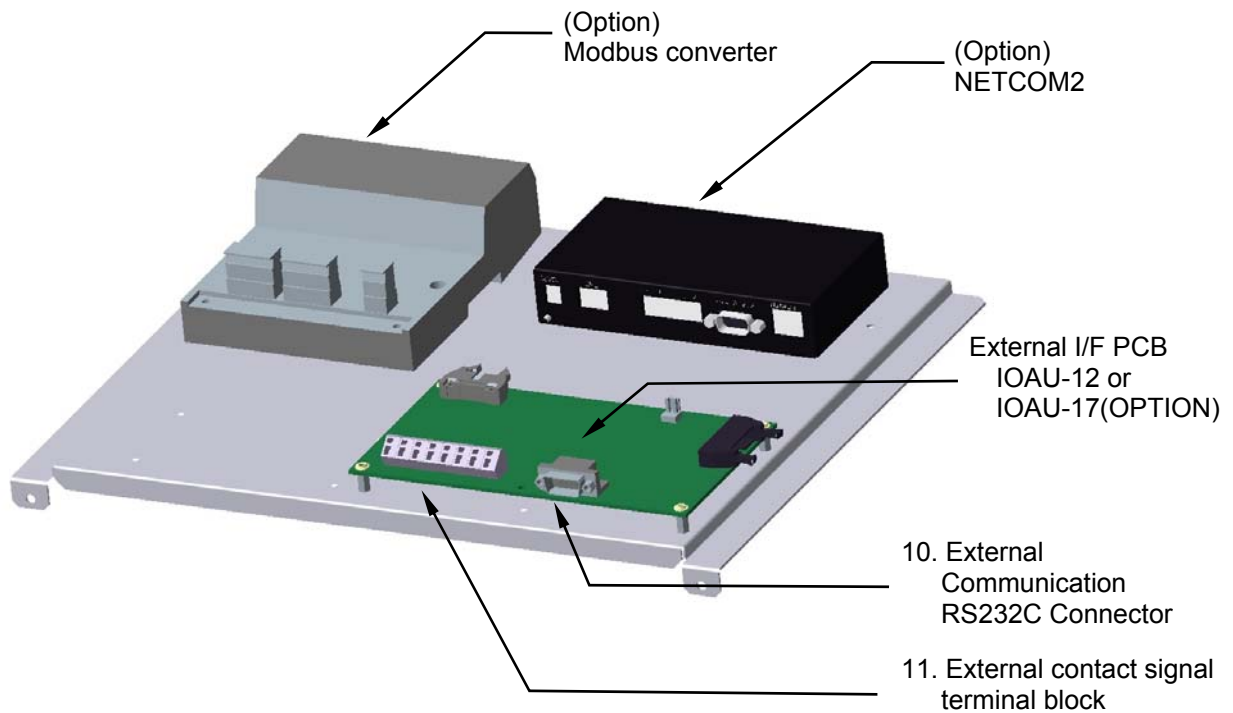

**Description of UPS parts, referred to in Figure 1.4 to Figure 1.7:****1. LCD Touch Panel Monitor Display**

The liquid crystal display (LCD) touch panel monitor display indicates power flow, measured values and fault and error messages via user selectable display screens.

Refer to FIGURE 2.1 for details.

**2. Maintenance Bypass Switch**

This switch activates the bypass power supply for emergency reasons if the UPS is turned off.

**3. AC input, AC output, DC input terminal**

Refer to Figure 3.9 for details

**4. Grounding Bar (E)****5. "RESET" switch (FOR SERVICE PERSONNEL ONLY)**

This switch resets errors resulting from alarm conditions.

**6. "IL" switch (FOR SERVICE PERSONNEL ONLY)**

This switch inhibit to start UPS.

**7. "MAINTENANCE" switch (FOR SERVICE PERSONNEL ONLY)**

This switch sets the UPS menu parameters.

**8. "LOAD ON BYPASS" switch (FOR SERVICE PERSONNEL ONLY)**

This switch is used to transfer the UPS from inverter to static bypass for maintenance purposes. Do not operate it under normal operation. Transfers will be locked-out if the bypass voltage is more than  $\pm 10\%$  of nominal. Uninterrupted switching is made at the time of synchronous operation. Switching is impossible at the time of asynchronous operation.

**9. "LOAD ON INVERTER" switch (FOR SERVICE PERSONNEL ONLY)**

This switch is used to transfer the UPS from static bypass to inverter for maintenance purposes.

**10. External communication RS232C connector (Figure 1.7)**

Refer to FIGURE 2.25 for details.

**11. External contact signal terminal block (Figure 1.7)**

Terminal block to connect contact signal input/output lines to and from external dry contacts.

Refer to FIGURE 2.21 and FIGURE 2.22 for details.

## 1.5 SPECIFICATIONS

The UPS name plate displays the rated kVA as well as nominal voltages and currents.  
The nameplate is located on the top of the UPS cabinet.

**Table 1.3** Power Specifications

Rated output Power	Input voltage 3 ph / 4 wire	Output voltage 3 ph / 4 wire
10kVA / 9kW 20kVA / 18kW 30kVA / 27kW 40kVA / 36kW 50kVA / 45kW 60kVA / 54kW 70kVA / 63kW 80kVA / 72kW	120V / 208V	120V / 208V

**Table 1.4** UPS Module Cabinet Information

UPS (kVA)	CABLE ENTRY	WIDTH (in/mm)	DEPTH (in/mm)	HEIGHT (in/mm)	WEIGHT (lb./kg)	HEAT LOSS (kBTU/h)
10	TOP or BOTTOM	31.5 / 800	27.0 / 685	67.3 / 1710	498 / 226	2.3
20	TOP or BOTTOM	31.5 / 800	27.0 / 685	67.3 / 1710	542 / 246	4.6
30	TOP or BOTTOM	31.5 / 800	27.0 / 685	67.3 / 1710	586 / 266	6.9
40	TOP or BOTTOM	31.5 / 800	27.0 / 685	67.3 / 1710	631 / 286	9.2
50	TOP or BOTTOM	31.5 / 800	27.0 / 685	67.3 / 1710	675 / 306	11.6
60	TOP or BOTTOM	31.5 / 800	27.0 / 685	67.3 / 1710	719 / 326	13.8
70	TOP or BOTTOM	31.5 / 800	27.0 / 685	67.3 / 1710	763 / 346	16.1
80	TOP or BOTTOM	31.5 / 800	27.0 / 685	67.3 / 1710	807 / 366	18.4

**Table 1.5** Detail of Specifications

Type	UP1133B-A103SU-2	UP1133B-A203SU-2	UP1133B-A303SU-2	UP1133B-A403SU-2	UP1133B-A503SU-2	UP1133B-A603SU-2	UP1133B-A703SU-2	UP1133B-A803SU-2
Rated Output kVA	10	20	30	40	50	60	70	80
Rated Output kW	9	18	27	36	45	54	63	72
<b>AC INPUT CHARACTERISTICS</b>								
Configuration	3-phase, <b>3-wire</b> , plus ground							
Voltage	120/208 V +15% ~ -30%							
Frequency	60 Hz +/- 10%							
Reflected Current THD	4% typical at 100% load; 7% typical at 50% load							
<b>BYPASS INPUT</b>								
Configuration	3-phase, 4-wire, plus ground							
Voltage	120/208 V +10%							
Frequency	60 Hz +/- 10%							
<b>AC OUTPUT</b>								
Configuration	3-phase, 4-wire							
Voltage	120/208 V							
Voltage Stability	+/-1%							
Frequency	60 Hz							
Frequency Stability	+/-0.01% in free running mode							
Power Factor	0.9 nominal							
Power Factor range	0.9 ~ 1.0 lagging (within output kW rating)							
Voltage THD	2% typical THD at 100% linear load 5% typical THD at 100% non-linear load							
Transient Response	+/-3% typical at 100% load step +/-1% typical at loss/return of AC power +/-5% typical at load transfer to/from static bypass							
Transient Recovery	16.7 ms							
Voltage Unbalance	2% typical at 100% unbalanced load							
Phase Displacement	1deg. typical at 100% load							
Inverter Overload	125% for 60 seconds, 150% for 30 seconds							
System Overload	1000% for 1 cycle (with bypass available)							
Crest Factor Capabilities	2.5 : 1							
<b>ENVIRONMENTAL</b>								
Cooling	Forced Air							
Operating Temperature	32 deg F ~ 104 deg F (0 deg C ~ 40 deg C). Recommended 59 deg F ~ 77 deg F (15 deg C ~ 25 deg C)							
Relative Humidity	5% ~ 95% Non Condensing							
Altitude	0 ~ 7400 feet. (0 ~ 5000 feet No De-rating at 40 deg C)							
Location	Temperature-controlled, indoor area free of conductive contaminants							
Paint Color	Munsell N1.5 (Black)							

**Table 1.6** Rating of Contactors and Fuses

Component	Description	Component Rating @ 208V, 3-phase, 60 Hz							
		UPS Rating (kVA)							
		10	20	30	40	50	60	70	80
CB3	Static Bypass Input Contactor	135A	135A	135A	135A	135A	135A	135A	135A
52S	Static Bypass Contactor	285A	285A	285A	285A	285A	285A	285A	285A
F6,F7,F8	AC Input Fuse	660V / 60A							
F4,F5	Battery Input Fuse	660V / 60A							
F9,F10,F11	AC Output Fuse	660V / 60A							
F2,F3	Control Power	250V / 2A							
F1	Control Power	500V / 5A							



## 2 OPERATOR CONTROLS AND INDICATORS

The 1100 Series operator controls and indicators are located as follows:

**Figure 2.1** Operation/Display Panel (Front panel)

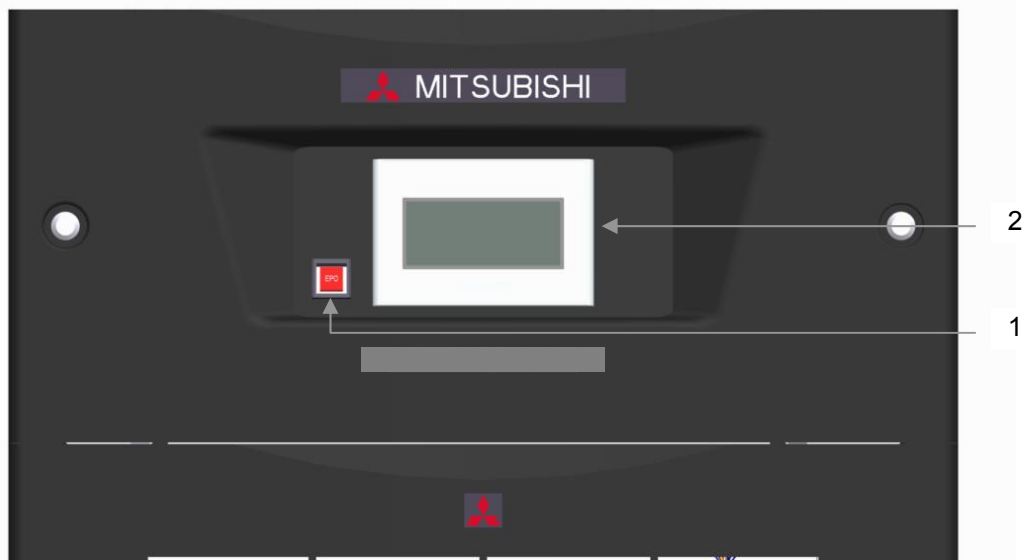

### 2.1 EMERGENCY POWER OFF BUTTON

When activated, the Emergency Power Off (EPO)(1) function shuts down the UPS module. The critical load will lose power and also shutdown. The EPO function can be performed both locally or remotely.

### 2.2 LIQUID CRYSTAL DISPLAY

The Liquid Crystal Display (LCD)(2) touch panel indicates power flow, measured values, operational guidance, data records and error messages. The LCD panel has a back-light which facilitates viewing in different ambient lighting conditions.

**2.2.1 MENU**

Refer to FIGURE 2.20 for the SCREEN MENU tree.

**A) MAIN MENU (FIGURE 2.2)**

The LCD panel indicates power flow and measured values, while also operating the start/stop function. The LCD panel also allows the user to verify the status and operation of the UPS Module.

**Figure 2.2 Main screen**

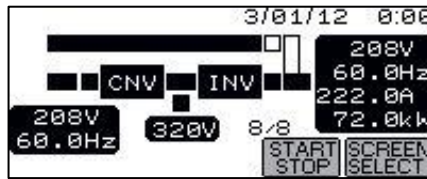

The following will be displayed when the START/STOP key on the SCREEN SELECT MENU (FIGURE 2.5) is pressed (Jump into **OPERATION MENU**):

**1) Startup/Shutdown Guidance (FIGURE 2.3, FIGURE 2.4)**

The display indicates the Startup and Shutdown guidance for the UPS system. If this operation is PIN protected, the user is required to enter the security PIN before the screen can be accessed.

When in remote mode, the message "REMOTE operating model" will appear on this Screen. The user cannot operate the start and stop functions without changing the setup from remote mode to local mode.

When bypass voltage is abnormal, the message "Bypass voltage abnormal" will appear.

- **Stop:** When the bypass voltage is abnormal, the user cannot transfer from inverter to bypass line.

**Figure 2.3 Startup guidance**



**Figure 2.4 Shutdown guidance**

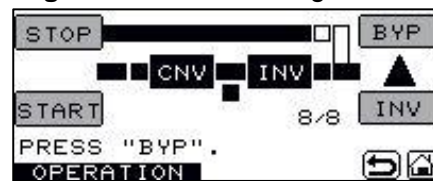

Follow Startup/Shutdown guidance accordingly.

**2) SCREEN SELECT MENU (FIGURE 2.5)**

This screen shows all screen menus.

**Figure 2.5 Screen select menu**

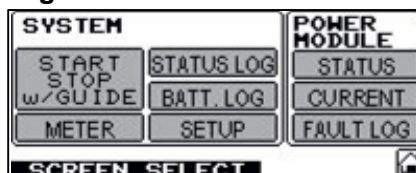

**A) MEASUREMENT MENU (FIGURE 2.6 – FIGURE 2.9)**

The following will be displayed when the METER key on the SCREEN SELECT MENU is pressed. This screen displays details of measured values for input and output. During battery operation, remaining battery power and run time are also displayed.

When the CURRENT key on the SCREEN SELECT MENU is pressed, output current of each individual module is displayed.

**Figure 2.6** Input values



**Figure 2.7** Output values

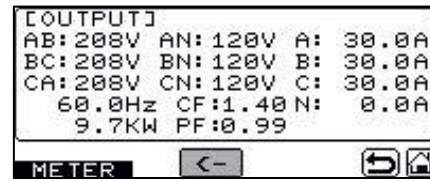

**Figure 2.8** Measurement during Battery operation

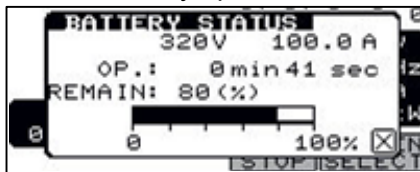

**Figure 2.9** Each Power Converter Module Output Current

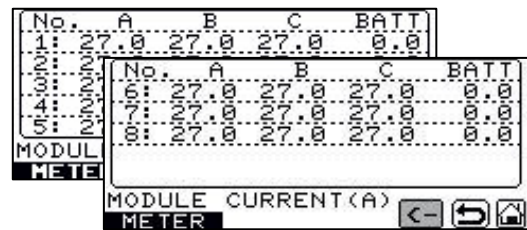

**B) LOG (FIGURE 2.1 0– FIGURE 2.13)**

Pressing the STATUS LOG icon on the SCREEN SELECT MENU, up to 50 condition/operation records will be displayed. Press “→” or “←” button for page turning.

Pressing the BATT.LOG icon, number of battery operations and cumulative battery operation time are displayed.

Pressing the F.LOG icon, up to 20 the power converter module failure records will be displayed. Press “→” or “←” button for page turning.

**Figure 2.10** Status log



**Figure 2.11** Battery log

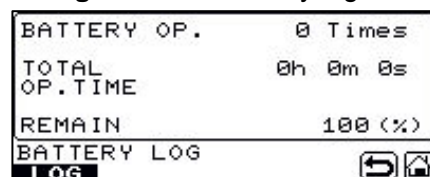

**Figure 2.12** Power Converter Failure log  
Select module number

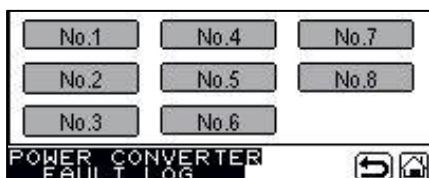

**Figure 2.13** Power C onverter Failure log

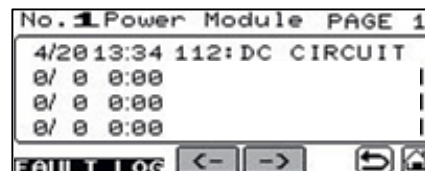

**C) SETUP MENU (FIGURE 2.14, FIGURE 2.15)**

The following will be displayed when the SETUP key on the SCREEN SELECT MENU is pressed.

This screen prompts the user to select: (FIGURE 2.14) whether the start & stop operation will be performed by local or remote operation; (FIGURE 2.15) time & date adjustment.

**Figure 2.14 Remote/Local operation select**



**Figure 2.15 Date & Time adjustment**



**2.2.2 INPUT POWER FAILURE (FIGURE 2.16, FIGURE 2.17)**

During an input power failure, the UPS inverter will be powered by the UPS batteries. The following will be displayed on the main and measurement screen (Indication of battery operation and remaining battery life).

**Figure 2.16 Main screen (Battery operation)**

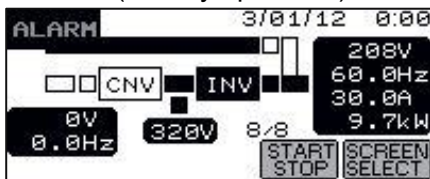

**Figure 2.17 Measurement screen**

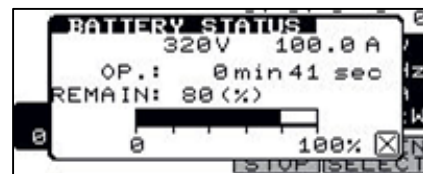

The LCD will display a battery low voltage message when the battery capacity is near depletion. The End of Battery Discharge announcement is displayed when the battery end voltage is reached. At this time, the inverter will perform an electronic shutdown to prevent battery loss of life typical from extreme deep discharge conditions. When the input power is restored, the inverter will automatically restart to power the load, and the batteries will be simultaneously recharged.

**2.2.3 FAULT INDICATION (FIGURE 2.18)**

ALARM icon will appear on the main menu (top left) when an UPS failure condition has occurred.

**Figure 2.18** Main screen (Fault indication)

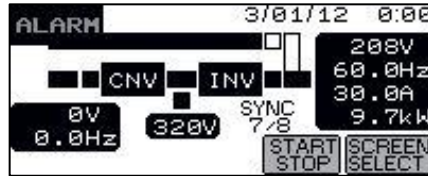

The following will be displayed when the ALARM icon on the main menu is pressed.

**1) ALARM MESSAGE (FIGURE 2.19)**

The display shows a fault code, the description of the fault and a guidance of what action is to be taken by the user. A maximum of 20 faults is displayed at one time.

**Figure 2.19** Message screen



**2) SILENCE ALARM**

This icon will appear when a failure occurs. The audible alarm (announcing the failure) can be silenced by pressing this icon.

**3) MODULE NUMBER**

This icon will appear when the module failure occurs. The module fault detail will be displayed when this icon is pressed. (Figure 2.13)

Figure 2.20 MENU Tree

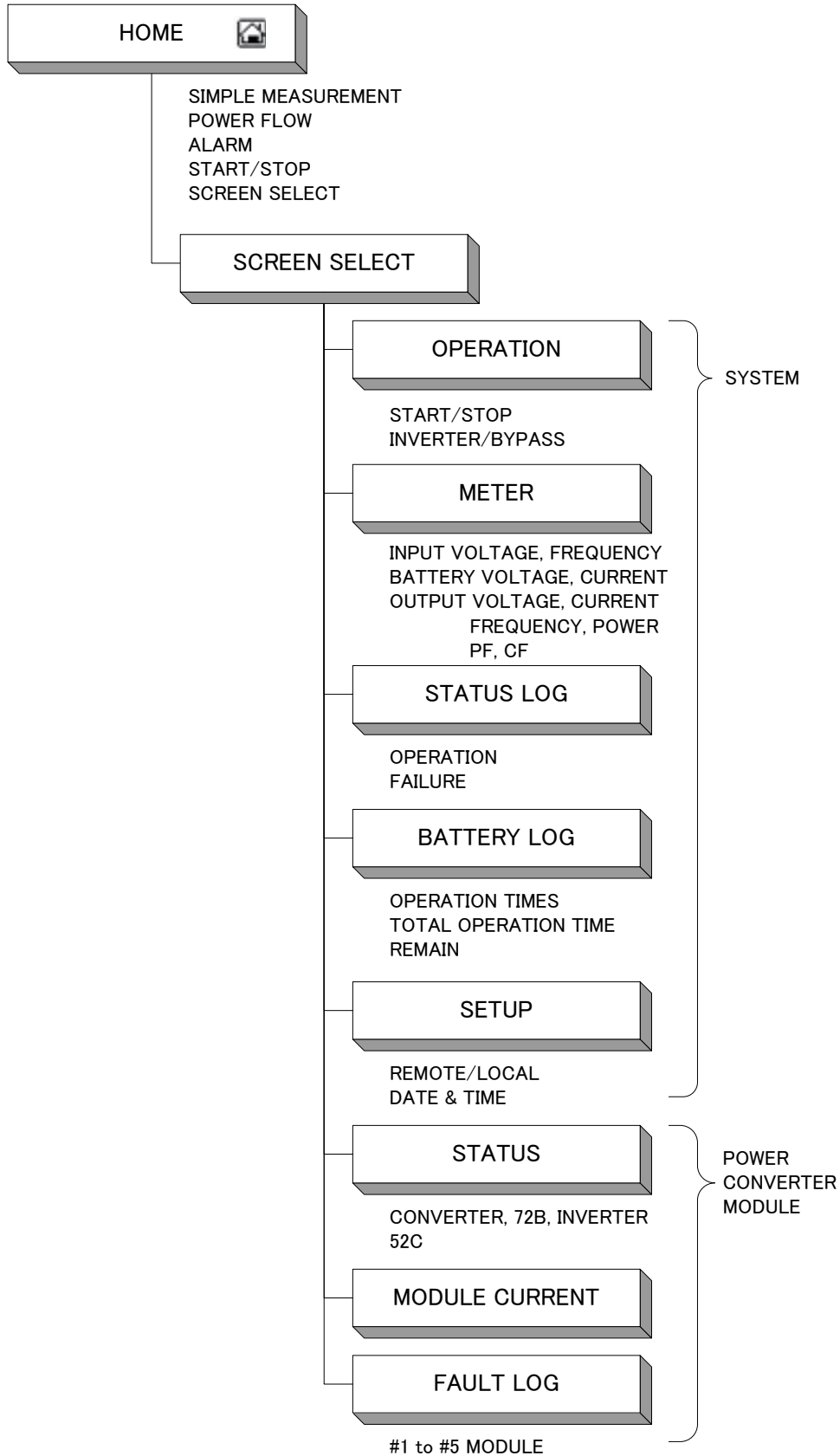

### 2.3 EXTERNAL SIGNAL TERMINAL BLOCK

The UPS is equipped with a series of input/output terminals for external annunciation of alarms and for remote access of certain UPS functions. The layout of terminals is shown in Figure 2.21 and Figure 2.22 with a functional description of the input/output port presented. Optional output port OUT1 to OUT7 are user programmable, but are factory default set being also shown in Figure 2.21.

Optional input port IN1 to IN4 are user programmable, but are factory default set being also shown in Figure 2.22.

**Figure 2.21 External Signal Terminal Block (NEC Class2)**

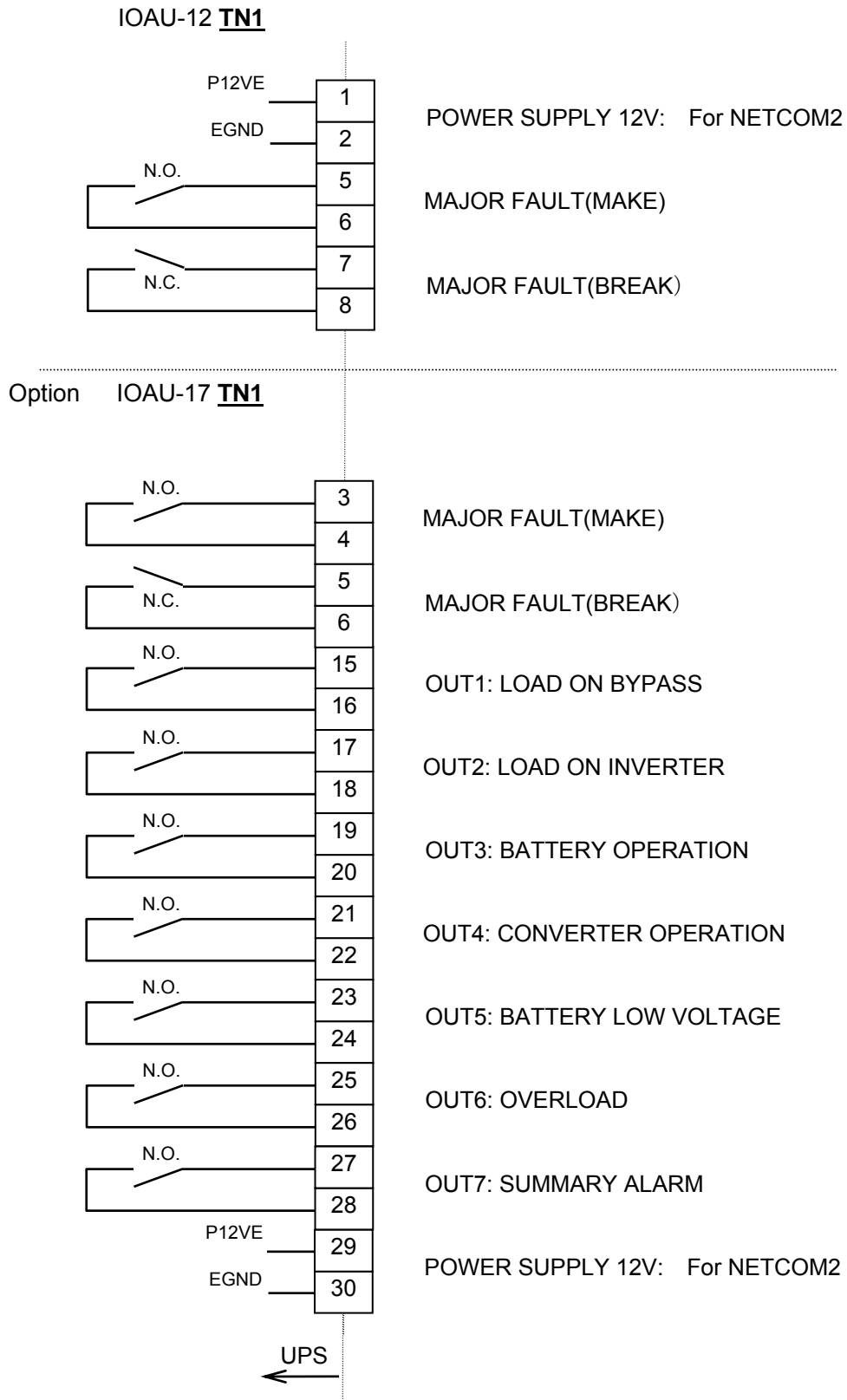



**Figure 2.22** External Signal Terminal Block (NEC Class2)

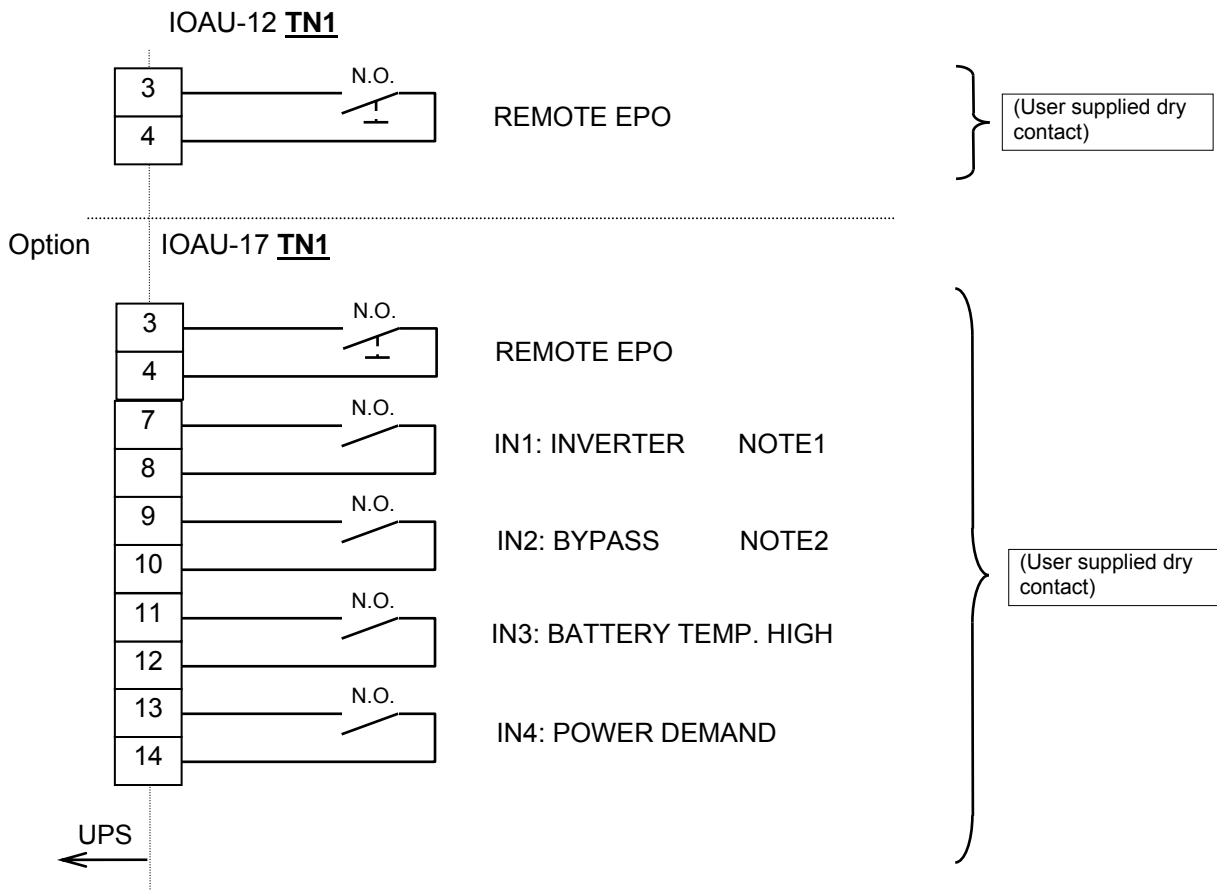

NOTE1: Remote transfer operation from BYPASS to INVERTER.

NOTE2: Remote transfer operation from INVERTER to BYPASS.

UPS direct operation is required for INVERTER START/STOP control.

**A) Output Contacts (for external alarm annunciation)**

Output contacts consist of form “A” dry type contacts. Rated capacity of all output contacts is NEC Class2 (30Vdc/1A dc). All dry contacts should be operated at their rated values or lower. Figure 2.23 illustrates a typical installation. The external relay can also be a lamp, LED, computer, etc.

**Figure 2.23** Control Wiring for External Contacts

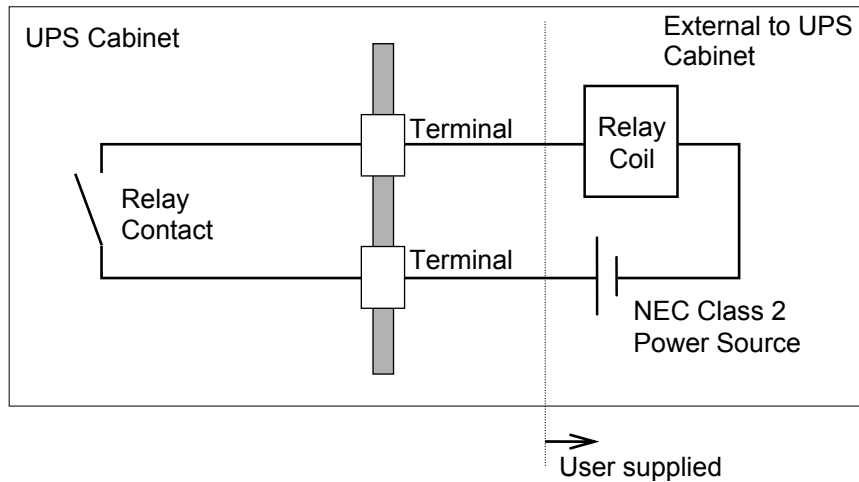

**Details of output alarm contacts : IOAU-12 TN1**

**Terminals 5 to 6 "Major fault(make)" contact**

Activated when a major fault has occurred with the system.

**Terminals 7 to 8 "Major fault(break)" contact**

Activated when a major fault has occurred with the system.



**NOTE**

**NOTE: The UPS is equipped with a selectable output contact feature.**

**The above alarms are the default settings.**

**Contact MITSUBISHI ELECTRIC POWER PRODUCTS, INC for setup information.**

**B) Input Contacts (for remote access of UPS)**

External contacts are provided by the user of the UPS system. Terminal voltage at the UPS is 24Vdc. Provide external dry contact accordingly.



**CAUTION**

**CAUTION: Do not apply voltages to remote access input terminals. Damage to UPS may result.**

Refer to Figure 2.24 for a typical wiring configuration. Although this figure applies to the remote start/stop terminals, the same wiring arrangement is used for emergency stop; power demand; and battery temperature high.

**Figure 2.24** Remote "Start" Contact Connections

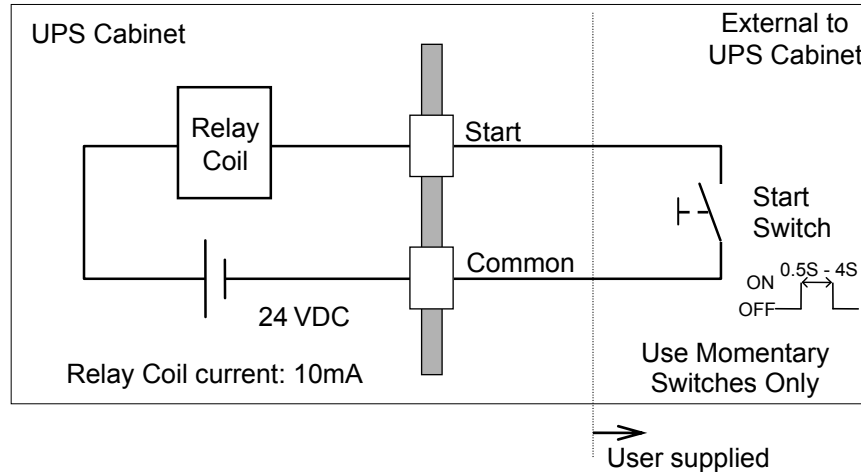

**Details of input contacts for remote access : IOAU-12 TN1**

**Terminals 3 to 4 "Remote EPO" contact input**

Used to perform a remote UPS Emergency Power Off (EPO).

**The load will be dropped.**

**NOTE:** The UPS is equipped with a selectable input contact item.

The above items are the default settings. MITSUBISHI ELECTRIC POWER PRODUCTS, INC for setup information.



**CAUTION:** In all cases, a switch having a protective cover is recommended in order to reduce the possibility of accidental operation.

## 2.4 EXTERNAL COMMUNICATION CONNECTOR

This is an RS232C port for “DiamondLink” monitoring software.  
The layout of connector is shown in Figure 2.25.

**Figure 2.25** External communication connector (NEC Class2)

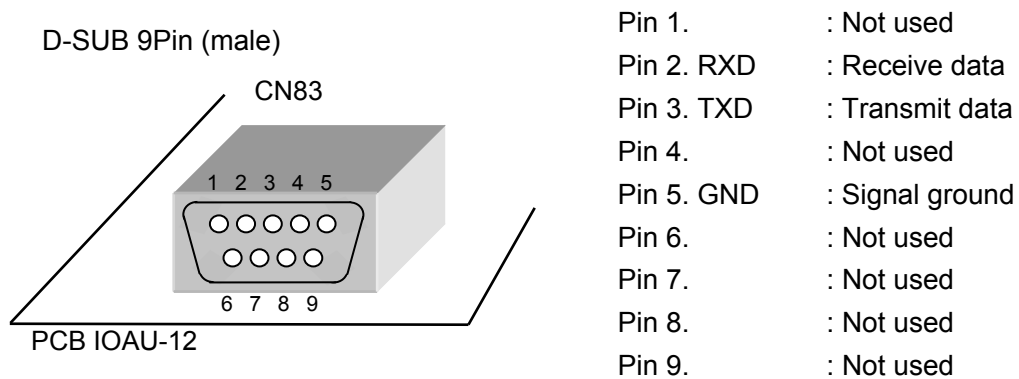

### NOTE

**NOTE :** Consult MITSUBISHI ELECTRIC POWER PRODUCTS, INC for details on “DiamondLink” monitoring software and its capabilities.

**3 INSTALLATION AND OPERATION**

**3.1 UPS COMPONENTS**

Refer to Table 3.1 for list of component weights:



**Table 3.1** List of UPS component weights

Component		Weight (lb.)
UPS Module cabinet only	80kVA cabinet	417
Power Converter Module		45
Bypass Module		25
Option I/F Module		5

**Figure 3.1** UPS Components

UPS Module cabinet  
(Empty cabinet)  
31.5W x 27D x 67.3H (in.)



Bypass Module  
19.3W x 25.2D x 7.6H (in.)  
Part No. THAU-06

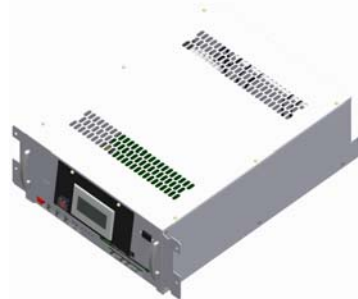

Power Converter Module  
19.3W x 25.2D x 5.9H (in.)  
Part No. PMAU-02



Option I/F Module  
14.8W x 12.2D x 1.5H (in.)  
Part No. 3AYA0683G001

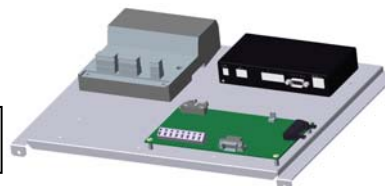

NetCom2, Modbus,  
are provided separately.

## 3.2 TRANSPORTATION AND INSTALLATION

**Table 3.2** How to transport and install the system

Transportation	Installation
Transport unit with forklift.	Pull out the UPS cabinet as shown in Figure 3.2 Fix the UPS unit in place using the four (4) leveling feet. Using the two (2) brackets (with pre-drilled hole (0.47" Diameter)), anchor the UPS using appropriate hardware (Not provided).



**NOTE:** Do not transport in a horizontal position. Cabinets should be maintained upright within +/- 15° of the vertical during handling.

**NOTE**

## 3.3 HANDLING

The UPS is shipped in export packaging. Remove the UPS from the package only when it is ready for installation.

**Figure 3.2 Handling**

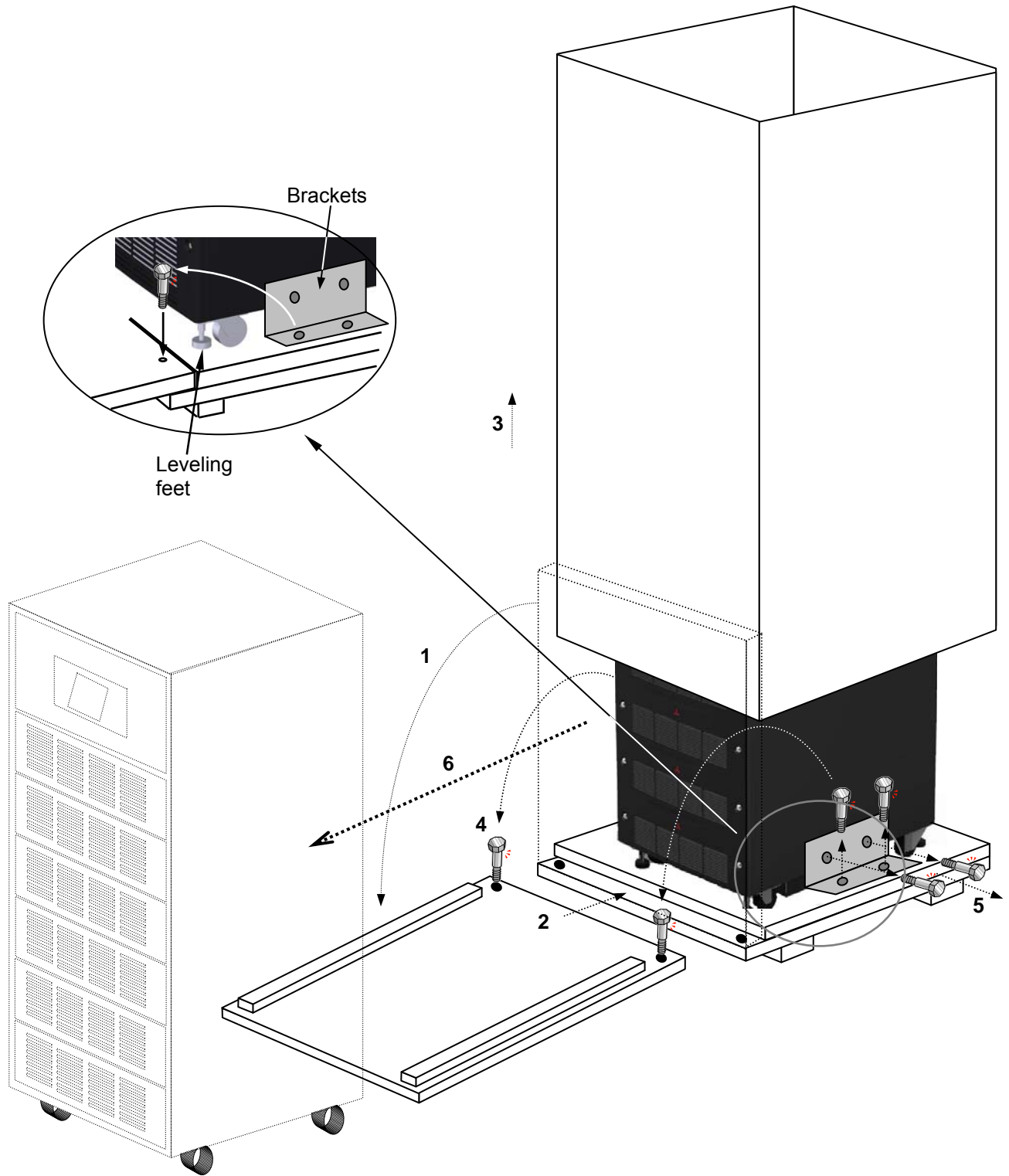

**3.4 INSTALLATION PROCEDURE**

**A) Note the load tolerance of the floor**

Refer to Table 3.3 for list of UPS weights:



**Table 3.3** List of UPS weights

UPS Capacity (kVA)	10	20	30	40	50	60	70	80
Weight (lb.)	498	542	586	631	675	719	763	807

**NOTE**

**B) Minimum clearance required for ventilation**

Right side ..... 1.0" (25 mm) (not required when sidecars are used)

Left side ..... 1.0" (25 mm) (not required when sidecars are used)

Back side ..... 8.0" (203 mm) (10kVA and 20kVA UPS refer to Figure 3.4)

Top side ..... 16.0" (406 mm)

**C) Space requirement for routine maintenance**

Allow for the following space at the time of installation.

Front ..... 31.5" (800 mm)

Sides ..... 1.0" (25 mm)

Rear ..... 8.0" (203 mm)

Top side ..... 16.0" (406 mm)

**Figure 3.3** Clearance for ventilation and maintenance

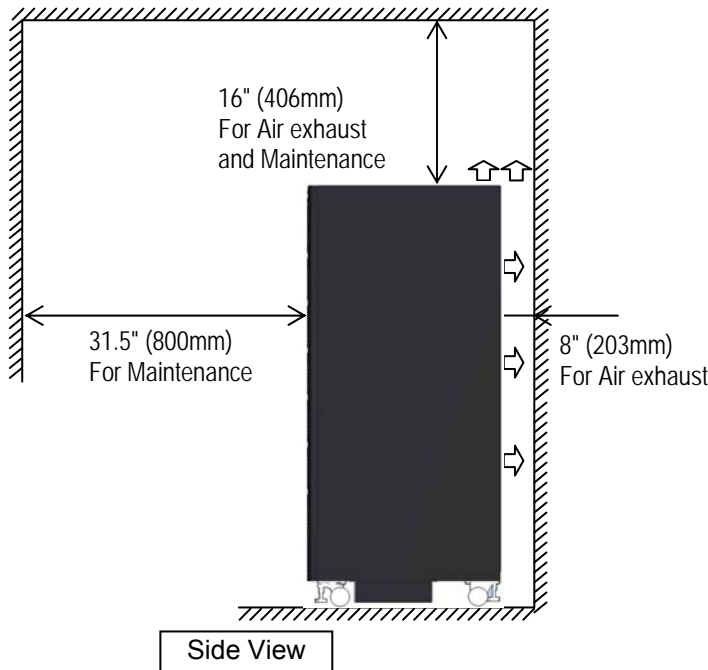



**Figure 3.4** Rear Clearance for ventilation and maintenance for 10kVA and 20kVA

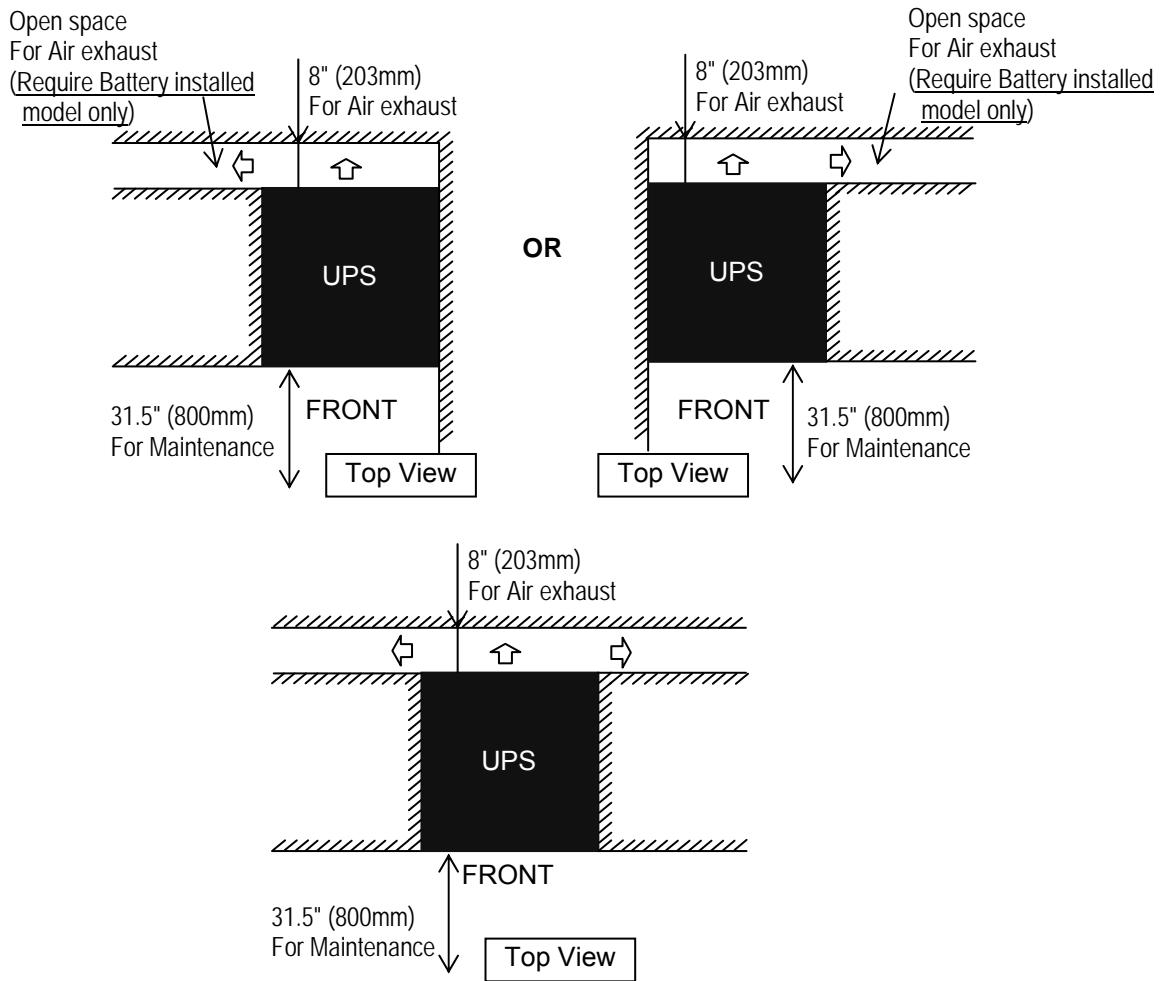

**D) External Battery (10kVA, 20kVA 30kVA, 40kVA 50kVA, 60kVA , 70kVA and 80kVA)**

Please refer to the following when installing and maintaining batteries:



1. The customer shall refer to the battery manufacturer's installation manual for battery installation and maintenance instructions.
2. The maximum permitted fault current from the remote battery supply and the DC voltage rating of the battery supply over-current protective device are shown in Table 3.5.

**Table 3.4** Maximum Permitted Fault Current

UPS Capacity (kVA)	DC Voltage Rating (V)	Maximum Fault Current Permitted (A)
10	288	25,000
20	288	25,000
30	288	25,000
40	288	25,000
50	288	25,000
60	288	25,000
70	288	25,000
80	288	25,000

**E) Installing Air Filter**

1. Remove Front Cover
2. Grip the air filter using three ledges  
Filter Size: 16W x 4.3H x 0.8D (in)

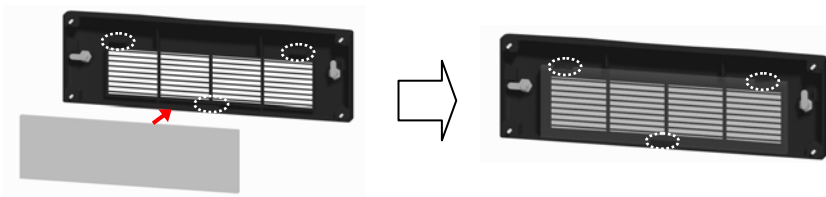

3. Close the front cover.

**F) Installing Power Converter Module and Bypass Module (FOR SERVICE PERSONNEL ONLY)**

**Figure 3.5** Install Power Converter Module and Bypass Module

**1. Remove Front Cover**

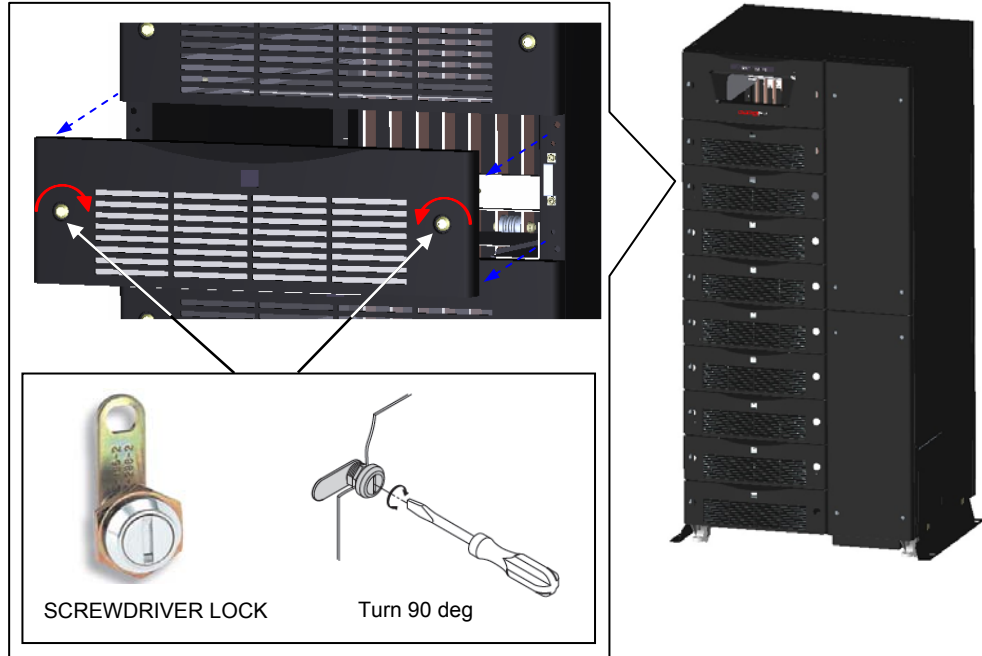

**2. Installing Modules**

Quantity of Modules

	Bypass Module	Power Converter Module
10kVA	One(1)	One(1)
20kVA	One(1)	Two(2)
30kVA	One(1)	Three(3)
40kVA	One(1)	Four(4)
50kVA	One(1)	Five(5)
60kVA	One(1)	SIX(6)
70kVA	One(1)	SEVEN(7)
80kVA	One(1)	EIGHT(8)



3. Fastening four(4) screws in each module.
4. Insert control wires.
5. Close front cover.



### 3.5 PROCEDURE FOR CABLE CONNECTIONS

1. Confirm the capacity of the UPS being installed. Identify the input/output power terminal blocks shown in Figure 3.7 or Figure 3.8.
2. Connect the grounding conductor from the input service entrance to the UPS ground bar.
3. Confirm that an external input circuit breaker sized to protect both the converter input and the bypass lines is installed. Consult equipment nameplate for current ratings. Connect the AC power source cables from the input service entrance to the UPS INPUT power terminals identified as A10, B10, C10 and N10 in Figure 3.9. Input cables must be sized for an ampere rating larger than the maximum current capacity of the UPS.
4. Refer to Table 3.6 for recommended cable sizes. Referring to Figure 3.9, connect UPS OUTPUT load terminals A40, B40, C40 and N10 to load distribution panel.
5. Connect external signal terminal block as needed. Refer to Section 2.3, **Figure 2.21** and **Figure 2.22** for functional description. AWG12, or less, shielded conductor is recommended.



**NOTE: UPS power terminals are supplied with stud type fittings. It is recommended that compression lugs be used to fasten all input/output power cables. Refer to Table 3.7 for recommended compression lugs and appropriate crimping tool**

**NOTE**

**Table 3.5** Recommended Cable Size and Torque Requirements

UPS Capacity (kVA)	AC Input Side * 1		DC Input Side		Bypass input Side * 1 Output Side * 1	
	Cable *2 Size	Torque (in. lbs)	Cable *2 Size	Torque (in. lbs)	Cable *2 Size	Torque (in. lbs)
10kVA	8 AWG	185~270	8 AWG	185~270	8 AWG	185~270
20kVA	4 AWG	185~270	4 AWG	185~270	4 AWG	185~270
30kVA	2 AWG	185~270	1 AWG	185~270	2 AWG	185~270
40kVA	1/0 AWG	185~270	2/0 AWG	185~270	1/0 AWG	185~270
50kVA	3/0 AWG	185~270	4/0 AWG	185~270	2/0 AWG	185~270
60kVA	4/0 AWG	185~270	2x 1 AWG	185~270	4/0 AWG	185~270
70kVA	2x 1 AWG	185~270	2x 1/0 AWG	185~270	2x 1 AWG	185~270
80kVA	2x 1/0 AWG	185~270	2x 2/0 AWG	185~270	2x 1/0 AWG	185~270

\*1 - Voltage drop across power cables shall not exceed 3% of nominal source voltage.

\*2 - Allowable ampere ratings based on 90 ° C insulation at an ambient temperature of 40 ° C.

No more than 3 conductors in a raceway without de-rating. Copper conductors assumed.



**NOTE: Intended to upgrade in future input/output/battery wiring and branch circuit protection will require upgrade.**

**NOTE**

**Table 3.6** Crimp Type Compression Lug

WIRE SIZE (CODE)	WIRE STRAND CLASS	RECOMMENDATION		CRIMP TOOL REQUIRED BURNDY TYPE Y35 OR Y46	
		VENDOR	CAT. NO.	COLOR KEY	DIE INDEX
8	B	BURNDY	YA8CL-2TC38	RED	49
4	B	BURNDY	YA4CL-2TC38	GRAY	8
2	B	BURNDY	YA2CL-2TC38	BROWN	10
1	B	BURNDY	YA1CL-2TC38	GREEN	11
1/0	B	BURNDY	YA25L-2TC38	PINK	12
2/0	B	BURNDY	YA26L-2TC38	BLACK	13
3/0	B	BURNDY	YA27L-2TC38	ORANGE	14
4/0	B	BURNDY	YA28L-2TC38	PURPLE	15



**NOTE:** When using crimp type lugs, the lugs should be crimped to the specifications given in the manufacturer's instructions for both crimp tool and lug.

**NOTE**

**Table 3.7** Recommended Hardware

UPS Capacity	Bolt size	Flat washer size	Split lockwasher size	Nut size
10kVA	M10 x 30mm	M10	M10	M10
20kVA	M10 x 30mm	M10	M10	M10
30kVA	M10 x 30mm	M10	M10	M10
40kVA	M10 x 30mm	M10	M10	M10
50kVA	M10 x 30mm	M10	M10	M10
60kVA	M10 x 30mm	M10	M10	M10
70kVA	M10 x 30mm	M10	M10	M10
80kVA	M10 x 30mm	M10	M10	M10

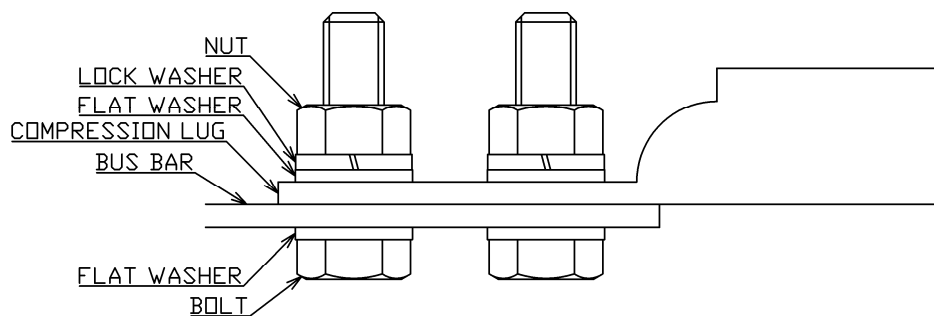
**Figure 3.6** Hardware configuration

**Figure 3.7** UPS Terminal Designation

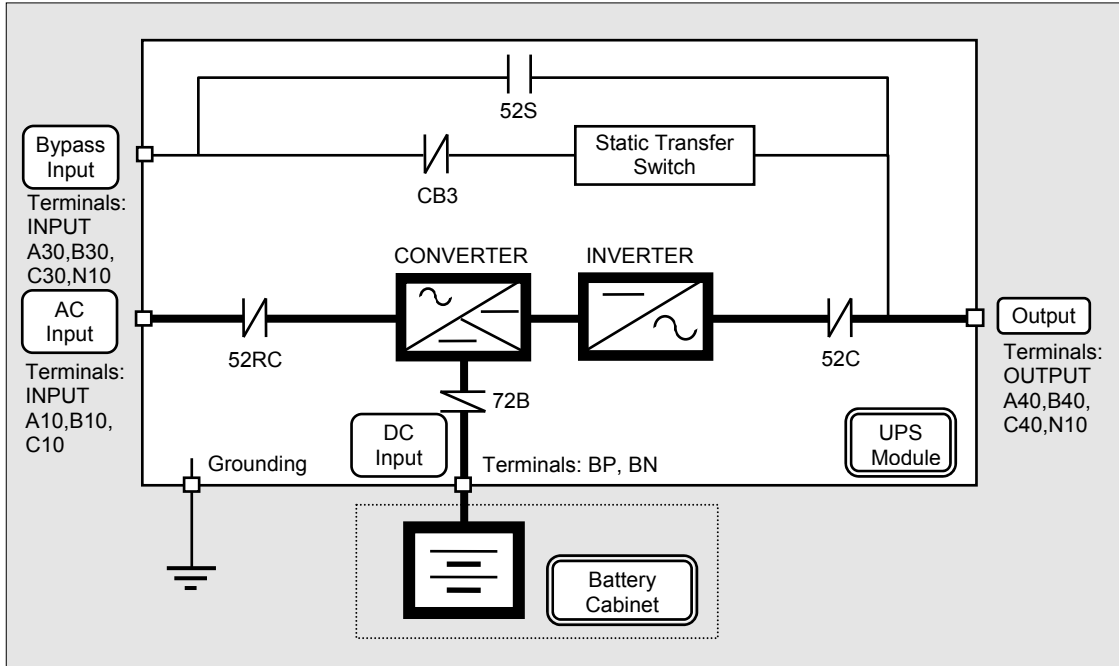

**Figure 3.8** Cable connection for dual input

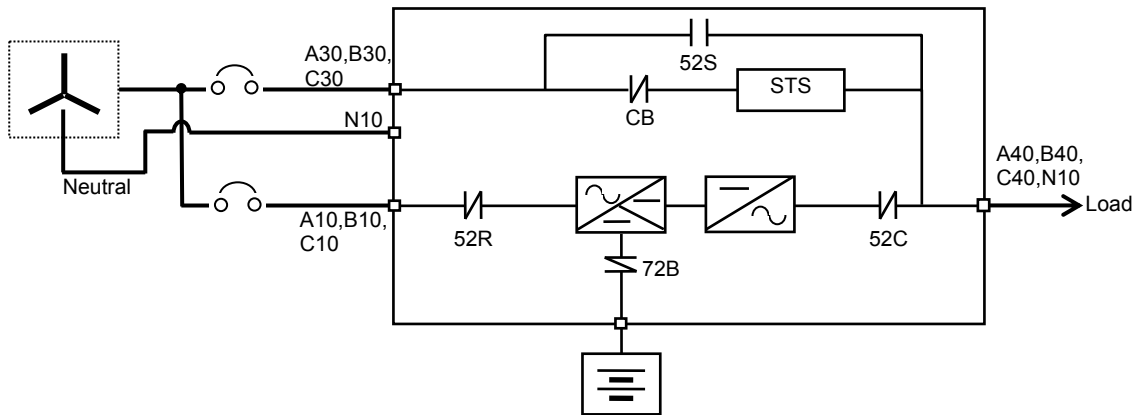

**Figure 3.9** Cable connection for single input

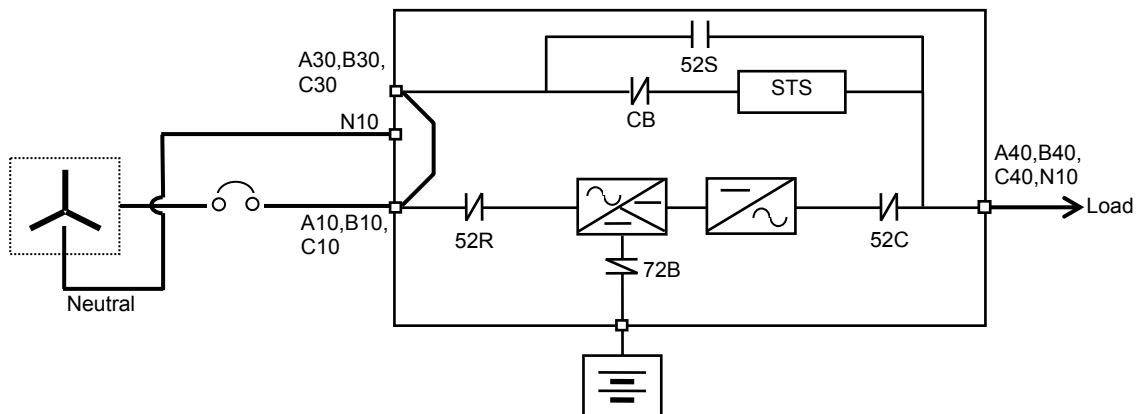

**Figure 3.10** Input/Output Power Terminals

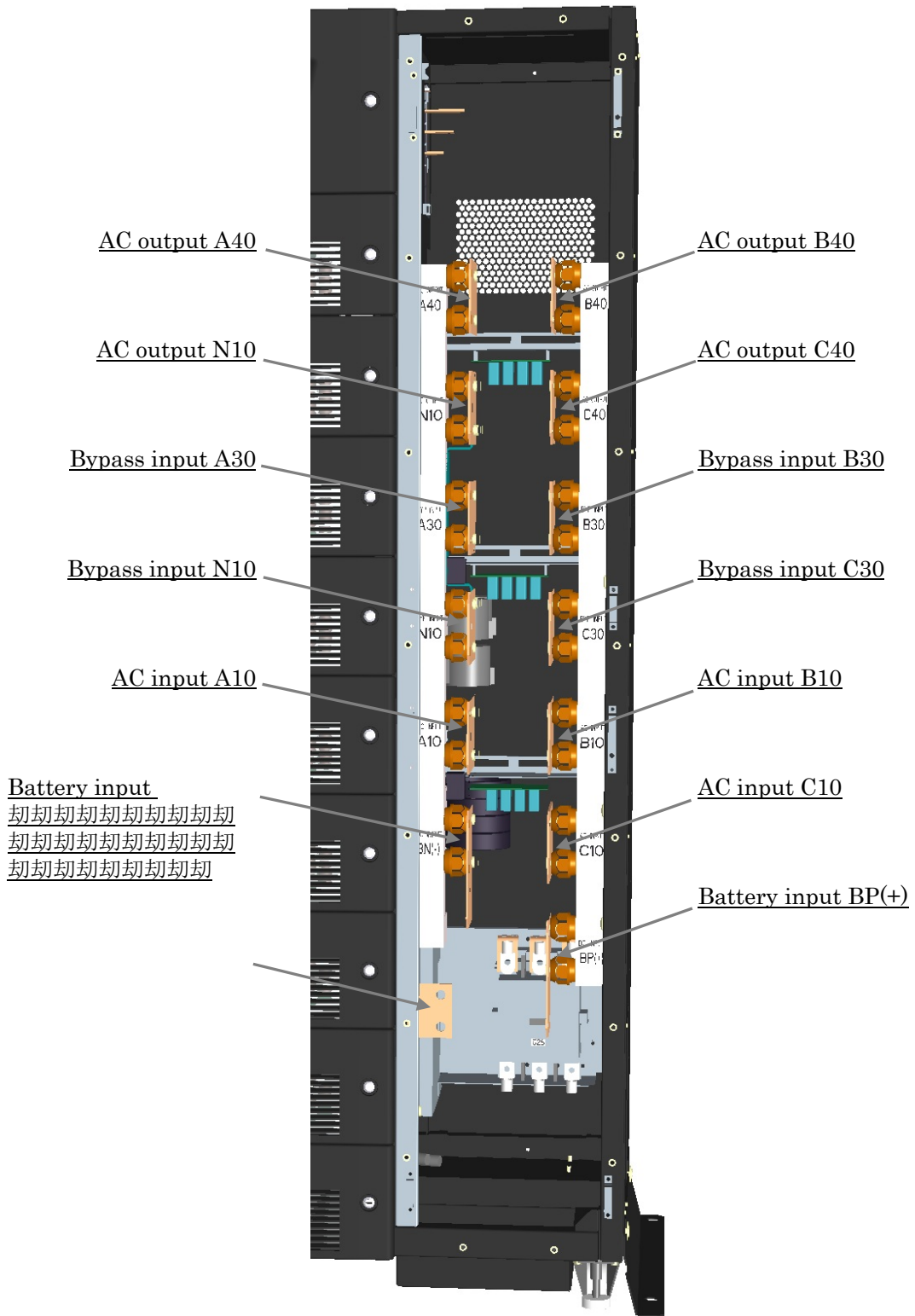

*ALL POWER TERMINALS USE 3/8" (10 mm) DIAMETER BOLTS*

**Figure 3.11** In case of Bottom Cable Entry

Z-shaped bracket is prepared for separation between AC cable and DC terminal or DC cable and AC terminal. AC cable to be laid under the Z-shaped bracket. DC cable to be laid upper the Z-shaped bracket. Z-shaped bracket is removable but to be attached to the cabinet frame after connecting cable to terminal.

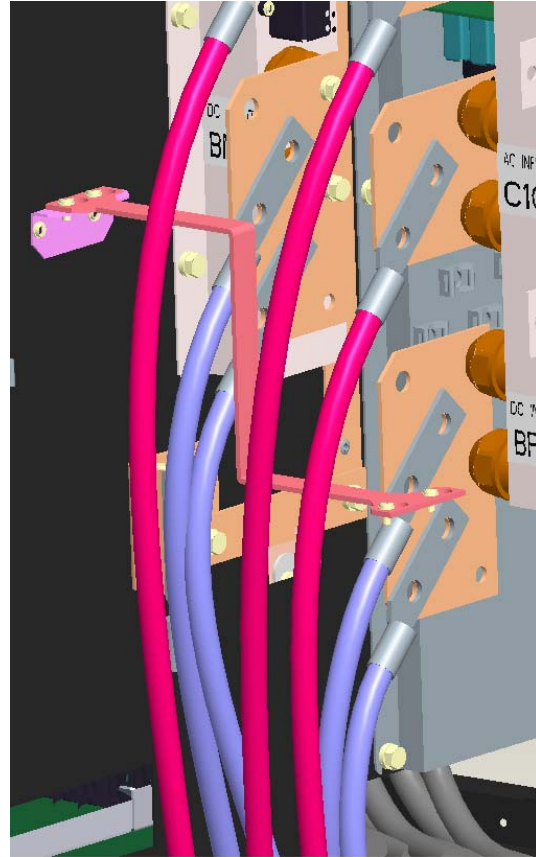
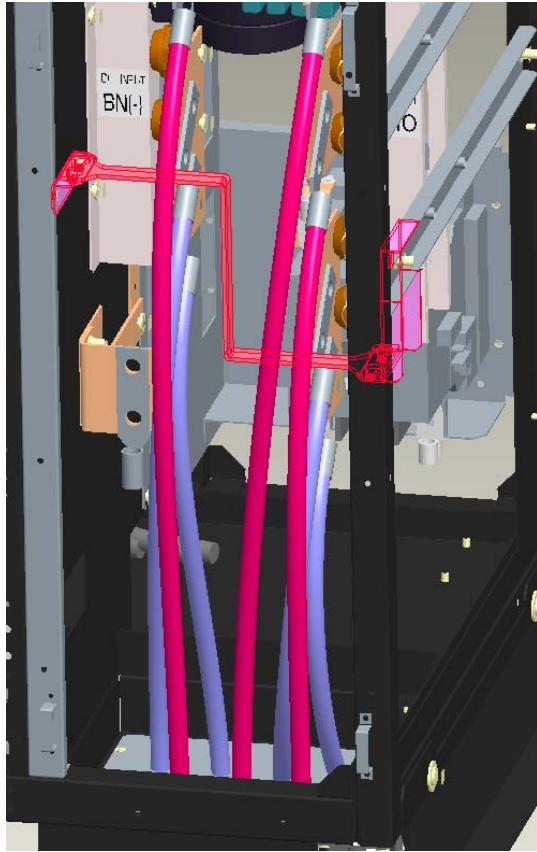



**Figure 3.12** In case of Bottom Cable Entry

Z-shaped bracket is prepared for separation between AC cable and DC terminal or DC cable and AC terminal. AC cable to be laid under the Z-shaped bracket. DC cable to be laid upper the Z-shaped bracket. Z-shaped bracket is removable but to be attached to the cabinet frame after connecting cable to terminal.

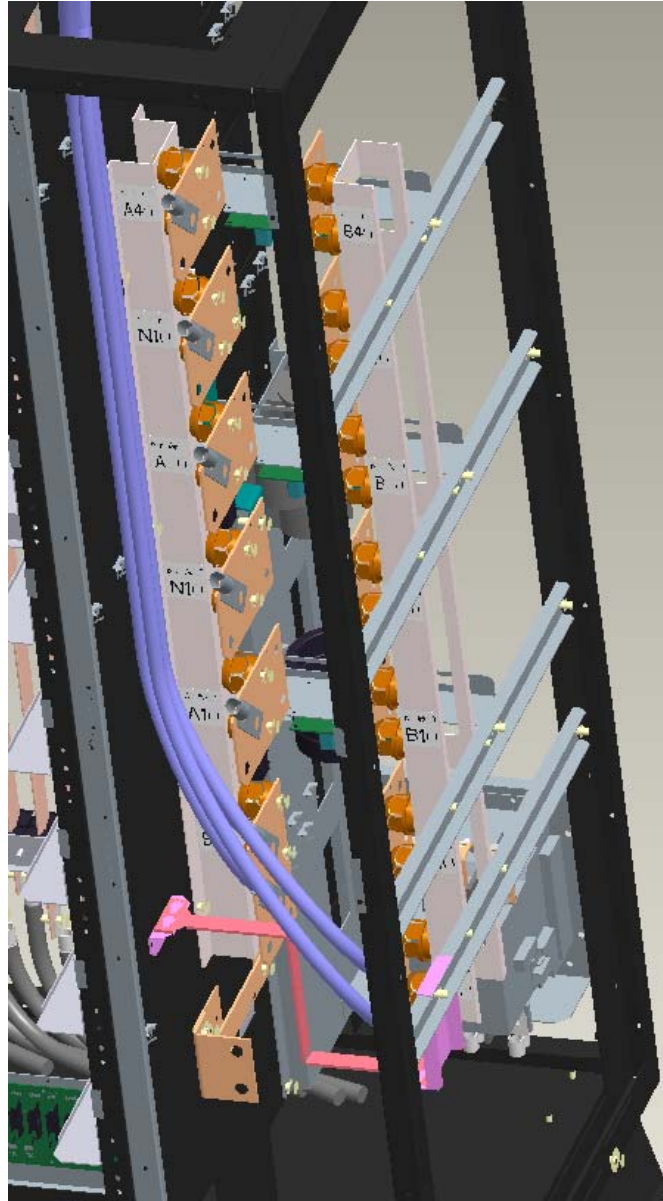

### 3.6 OPERATING PROCEDURES

#### A) UPS Start-up Procedure



**CAUTION:** Before the UPS startup, the internal bypass line starts to supply unconditioned bypass input power to the critical load when the external input circuit breaker is closed. Be extremely careful with closing the external input circuit breaker.



**NOTE**

**NOTE:** When "REMOTE OPERATION MODE" is displayed on the LCD panel, the inverter start operation can only be performed remotely. If local inverter start operation is required (at the UPS), select "LOCAL ONLY" or "REMOTE & LOCAL" in the OPERATION MENU.

1. Verify that the external input circuit breaker is closed (User supplied. Refer to Warning 4).
2. The LCD panel boots up automatically, and the screen will show that the load is powered through the bypass line.
3. On the LCD panel, press the "START/STOP" button to proceed UPS start-up. (Refer to 2.2.1).
4. Follow the "STARTUP GUIDANCE" accordingly until the completion of the inverter startup.

#### B) UPS Shutdown Procedure



**NOTE**

**NOTE:** When "REMOTE OPERATION MODE" is displayed on the LCD panel, the inverter start operation can only be performed remotely. If local inverter start operation is required (at the UPS), select "LOCAL ONLY" or "REMOTE & LOCAL" in the OPERATION MENU.

1. On the LCD panel, press the "START/STOP" icon to proceed UPS shutdown. (Refer to 2.2.1)
2. Follow the "SHUTDOWN GUIDANCE" accordingly. During the procedure, UPS will transfer the power feeding from the inverter supply to the bypass line supply.
3. Both converter and inverter will remain energized until complete disconnection from all power sources.

**WARNING**

**WARNING:** Verify the load is OFF if the next step is to be performed.

**NOTE**

**NOTE:** Power to the critical load is supplied through the static bypass line. Power to the critical load will be lost after execution of the next step. The load will drop.

4. To shutdown the critical load, open the external input circuit breaker (User supplied.).

**CAUTION**

**CAUTION:** In bypass mode, all UPS power terminals are still live. Lethal voltages are present. De-energize all external sources of AC and DC power. Before removing the covers, wait 5 minutes after de-energizing. Check no-voltage before handling UPS. Be careful for the devices even when the UPS has been de-energized. Internal devices may be hot.

#### C) EPO (Emergency Power Off) Procedure

If an all power supply shutdown is required in an emergency situation, press the "EPO" button on the front panel. The UPS will be shutdown and no power is supplied to the load.

**WARNING**

**WARNING:** With EPO operation, although all output power from the UPS is shutdown, it is necessary to manually open the input circuit breaker (user supplied), to remove the input power to the UPS.

### 3.7 MAINTENANCE BYPASS SET-UP PROCEDURES

**NOTE**

**NOTE:** Consult MITSUBISHI ELECTRIC POWER PRODUCTS, INC for External Maintenance Bypass Panel.

#### A) Load transfer from inverter to external maintenance bypass

1. On the LCD panel, press the "START/STOP" icon to proceed UPS shutdown. (Note: inverter STOP function inhibited if bypass and inverter are out of sync.)
2. Confirm via the flow diagram on the LCD that the load is fed from the UPS static bypass line.

3. Close the maintenance bypass circuit breaker in external maintenance bypass panel (MBP).
4. Open UPS output circuit breaker in MBP.
5. Transfer complete. Load is now powered from the external source. UPS can be shutdown.

**B) Transfer of load from external maintenance bypass to inverter**

1. Verify that the external input circuit breaker is closed.
2. Confirm via the flow diagram on the LCD that the UPS output is fed from the static bypass line.
3. Close UPS output circuit breaker in MBP.
4. Open the Maintenance bypass circuit breaker in MBP.
5. On the LCD panel, press the "START/STOP" button to proceed UPS start-up. (Refer to 2.2.1).
6. Transfer complete. Load now is powered by the inverter.

#### 4 RESPONSE TO UPS FAILURE

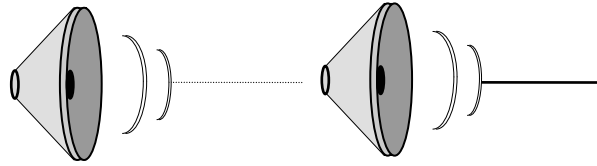
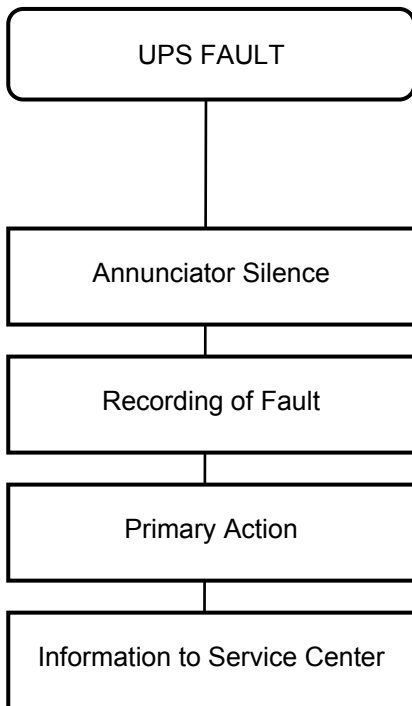

Depress "SILENCE ALARM" icon on Main Menu.

Refer to the list of fault codes in Section 6.0 for error description.

Take necessary action according to display guidance.

When faults happen, contact the Authorized Mitsubishi Electric Service Representatives or call Mitsubishi Electric at **1-800-887-7830**.



**NOTE**

**NOTE:**

**The error code indicated on the LCD display panel when an UPS alarms is very important.**

**In order to reduce repair time, please include this information, along with the operation and load status for all correspondence to Mitsubishi Electric Field Service Group.**

## **5 PARTS REPLACEMENT**

Contact Mitsubishi Electric Power Products, Inc. or its authorized service representatives on all issues regarding the replacement of parts.

### **A) Battery**

Battery lifetime may vary according to the frequency of use and the average ambient operating temperature. The end of battery life is defined as the state of charge resulting in an ampere-hour capacity less than, or equal to, 80% of nominal capacity.

Replace battery if its capacity is within this percentage.

### **B) UPS Component Parts**

UPS components have a defined life expectancy (Capacitors, Filters, etc).

Contact Mitsubishi Electric Power Products, Inc. or its authorized service representatives for a complete parts replacement schedule. Recommended replacement time interval varies with operating environment.

Contact Mitsubishi Electric Power Products, Inc. or its authorized service representatives for application specific recommendations.



#### **NOTE**

**NOTE: Any parts replacements (including modification) without authorized by Mitsubishi Electric could result in personal injuries, death or destruction of the UPS.**

## 6 FAULT CODES

This section covers fault codes, their description and required action.

In the event of a fault occurring:

Verify and record the occurrence of the alarm. Note details of alarm message displayed on the LCD display panel.

**Contact Mitsubishi Electric Power Products, Inc. at  
1-800-887-7830.**

## 6.1 BYPASS MODULE FAULT CODES

**Table 6.1** Bypass Module Fault Code List

Code indication (Note 2)	Status Message	Meaning	Guidance	Audible Alarm	External relay contact (Note 1)
UA805	INVERTER OVERLOAD	The output load current has exceeded 100% of the rated current.	WARNING: DECREASE LOAD	Intermittent sound	Overload Warning
UA806	INVERTER OVERLOAD	The output load current peak has exceeded 220% of the rated current.	WARNING: DECREASE LOAD	Intermittent sound	Overload Warning
UA807	INVERTER OVERLOAD	The output load current has exceeded 105% of the rated current.	WARNING: DECREASE LOAD	Intermittent sound	Overload
UA808	INVERTER OVERLOAD	The output load current has exceeded 100% of the rated current during bypass supply.	WARNING: DECREASE LOAD	Intermittent sound	Overload
UA812	BYPASS VOLTAGE OUT OF RANGE	Bypass line voltage is out of the specific range.	CHECK BYPASS INPUT	Intermittent sound	Bypass Input Abnormal
UA813	BYPASS PHASE ROTATION ERROR	Bypass line power conductors are not wired in a proper phase sequence.	CHECK BYPASS INPUT	Intermittent sound	Bypass Input Abnormal
UA814	BYPASS FREQUENCY OUT OF RANGE	Bypass line frequency is out of the specific range.	CHECK BYPASS INPUT	Intermittent sound	Bypass Input Abnormal
UA817	EMERGENCY STOP ACTIVATED	The emergency stop was activated by the EPO switch or an external contact.	-	Continuous sound	Alarm
UA819	REMOTE BUTTON ABNORMAL	Remote start signal is being received continuously for a considerable time.	-	Intermittent sound	Alarm
UA820	LOCAL BUTTON ABNORMAL	Local start or stop signal is being received continuously for a considerable time.	CALL SERVICE ENGINEER	Intermittent sound	Alarm
UA821	TRANSFER INHIBITION	The UPS cannot transfer to the bypass because the inverter output is not synchronized to the bypass.	-	-	Alarm
UA822	TRANSFER INHIBITION	The UPS cannot transfer to the bypass because of backup generator operation.	-	-	Alarm
UA824	72B OPEN	The battery disconnect contactor 72B in power converter module is opened.	-	-	Alarm
UA830	INTERLOCK SWITCH ON	Interlock switch was turned on.	-	Intermittent sound	Alarm
UA831	EMERGENCY BYPASS SWITCH ON	Emergency bypass switch has been turned on.	-	Intermittent sound	Alarm
UA834	BATTERY DEPLETED/AC OUT STOPPED	The battery voltage has reached the depleted level.	CALL SERVICE ENGINEER	Continuous sound	End-of-Discharge
UA835	TRANSFER INHIBITION	The UPS could not transfer to the bypass because the bypass source has an abnormality.	-	-	Alarm
UA861	MODULE ALARM	A power converter module has detected an alarm condition.	CALL SERVICE ENGINEER	Intermittent sound	Alarm
UA862	MODULE MINOR FAULT	A power converter module has detected a minor fault condition.	CALL SERVICE ENGINEER	Intermittent sound	Alarm
UA863	MODULE INPUT VOLTAGE OUT OF RANGE	A power converter module has detected input voltage abnormal.	CHECK INPUT POWER SOURCE	Intermittent sound	Alarm
UA864	MODULE OVERLOAD	A power converter module has detected output overload.	WARNING : DECREASE LOAD	Intermittent sound	Alarm



**Table 6.1 Bypass Module Fault Code List**

Code indication (Note 2)	Status Message	Meaning	Guidance	Audible Alarm	External relay contact (Note 1)
UA865	MODULE BATTERY DEPLETED	A power converter module has detected battery depleted.	CALL SERVICE ENGINEER	Intermittent sound	Alarm
UA866	MODULE BATTERY DEPLETED ALARM	A power converter module issues a warning on eminent battery depletion.	CALL SERVICE ENGINEER	Intermittent sound	Alarm
UA890	EXTERNAL ALARM	External alarm relay turned on.	-	Intermittent sound	Alarm
UF055	CONVERTER ABNORMAL	Mixed operation (20 seconds)	CALL SERVICE ENGINEER	Intermittent sound	Minor
UF151	BATTERY VOLTAGE ABNORMAL	All power converter modules have detected battery float voltage abnormal.	CALL SERVICE ENGINEER	Intermittent sound	Minor
UF156	CHG.STOPPED (BATTERY OVERTEMP.)	UF157 failure persisted for over two(2) hours.	CHECK BATTERY	Intermittent sound	Battery abnormal
UF157	BATTERY OVERTEMPERATURE	Detection of overtemperature at the batteries.	CHECK BATTERY	Intermittent sound	Battery abnormal
UF158	BATTERY LIQUID LOW	Low level of battery electrolyte solution.	CHECK BATTERY	Intermittent sound	Battery abnormal
UF161	CHG.STOPPED (DC VOLT. ABNORMAL)	UF151 failure is running for over 24 hours.	CALL SERVICE ENGINEER	Intermittent sound	Battery abnormal
UF162	BATTERY ABNORMAL	Failure detection based on battery self-check.	CALL SERVICE ENGINEER	Intermittent sound	Battery abnormal
UF163	BATTERY VOLTAGE ABNORMAL	All converter modules have detected battery voltage abnormal.	CALL SERVICE ENGINEER	Intermittent sound	Battery abnormal
UF202	OUTPUT UNDERVOLTAGE	Output voltage dropped.	CALL SERVICE ENGINEER	Intermittent sound	Minor
UF253	UPS CONTROL CIRCUIT ERROR	Discrepancy between output voltage and bypass voltage during bypass operation.	CALL SERVICE ENGINEER	Intermittent sound	Minor
UF254	UPS CONTROL CIRCUIT ERROR	Inverter voltage is out of the specification level during transfer.	CALL SERVICE ENGINEER	Intermittent sound	Minor
UF256	OUTPUT VOLTAGE ABNORMAL	Output voltage is out of the specified range.	CALL SERVICE ENGINEER	Intermittent sound	Minor
UF258	LOAD ABNORMAL	Load transfer due to overload for over 4 times within 5 minutes.	CALL SERVICE ENGINEER	Intermittent sound	Minor
UF301	UPS CONTROL CIRCUIT ERROR	AD reference has an abnormal value.	CALL SERVICE ENGINEER	Continuous sound	Major
UF302	UPS CONTROL CIRCUIT ERROR	Detection of an external interruption during the software execution.	CALL SERVICE ENGINEER	Continuous sound	Major
UF303	UPS CONTROL CIRCUIT ERROR	Timer does not reset in the specified period (WDT settings)	CALL SERVICE ENGINEER	Continuous sound	Major
UF305	UPS CONTROL CIRCUIT ERROR	Detection of an abnormal clock speed in the CPU or FPGA.	CALL SERVICE ENGINEER	Continuous sound	Major
UF306	UPS CONTROL CIRCUIT ERROR	Control power supply voltage is below the specified level.	CALL SERVICE ENGINEER	Continuous sound	Major
UF320	UPS CONTROL CIRCUIT ERROR	Cable disconnection in the parallel interface board during load supply.	CALL SERVICE ENGINEER	Intermittent sound	Minor

**Table 6.1** Bypass Module Fault Code List

Code indication (Note 2)	Status Message	Meaning	Guidance	Audible Alarm	External relay contact (Note 1)
UF323	UPS CONTROL CIRCUIT ERROR	Major communication error during parallel operation.	CALL SERVICE ENGINEER	Intermittent sound	Minor
UF340	MODULE MINOR FAULT	A power converter module has detected major fault condition.	CALL SERVICE ENGINEER	Intermittent sound	Minor
UF341	MODULE1 MAJOR FAULT	Power converter module #1 has detected major fault condition.	CALL SERVICE ENGINEER	Intermittent sound	Minor
UF342	MODULE2 MAJOR FAULT	Power converter module #2 has detected major fault condition.	CALL SERVICE ENGINEER	Intermittent sound	Minor
UF343	MODULE3 MAJOR FAULT	Power converter module #3 has detected major fault condition.	CALL SERVICE ENGINEER	Intermittent sound	Minor
UF344	MODULE4 MAJOR FAULT	Power converter module #4 has detected major fault condition.	CALL SERVICE ENGINEER	Intermittent sound	Minor
UF345	MODULE5 MAJOR FAULT	Power converter module #5 has detected major fault condition.	CALL SERVICE ENGINEER	Intermittent sound	Minor
UF349	MODULE MAJOR FAULT	All Power converter modules have detected major fault condition.	CALL SERVICE ENGINEER	Continuous sound	Major
UF351	CONTROL POWER SUPPLY ABNORMAL	Control power supply voltage is below the specified level. (Bypass)	CALL SERVICE ENGINEER	Intermittent sound	Minor
UF352	CONTROL POWER SUPPLY ABNORMAL	Control power supply voltage is below the specified level. (Output)	CALL SERVICE ENGINEER	Intermittent sound	Minor
UF353	CONTROL POWER SUPPLY ABNORMAL	External IO control power supply voltage is below the specified level.	CALL SERVICE ENGINEER	Intermittent sound	Minor
UF372	UPS CONTROL CIRCUIT ERROR	Unable to synchronize the inverter output and the bypass voltage.	CALL SERVICE ENGINEER	Intermittent sound	Minor
UF376	UPS CONTROL CIRCUIT ERROR	Logic signal abnormal (Supply ON).	CALL SERVICE ENGINEER	Intermittent sound	Minor
UF377	UPS CONTROL CIRCUIT ERROR	Logic signal abnormal (Supply OFF).	CALL SERVICE ENGINEER	Intermittent sound	Minor
UF401	52S ABNORMAL	Error to close the contactor 52S.	CALL SERVICE ENGINEER	Continuous sound	Major
UF402	52S ABNORMAL	Error to open the contactor 52S.	CALL SERVICE ENGINEER	Continuous sound	Major
UF452	CB3 ABNORMAL	Contactor CB3 is not working properly.	CALL SERVICE ENGINEER	Intermittent sound	Minor

## 6.2 POWER CONVERTER MODULE FAULT CODES

Code indication (Note 2)	Status message	Meaning	External relay contact (Note 1)
MA801	AC INPUT VOLTAGE OUT OF RANGE	Input line voltage is out of the specific range.	Alarm AC input abnormal
MA802	AC INPUT FREQUENCY OUT OF RANGE	Input line frequency is out of the specified range.	Alarm AC input abnormal
MA803	AC INPUT PHASE ROTATION ERROR	Input line power conductors are not wired in a proper phase sequence.	Alarm AC input abnormal
MA804	CONVERTER OPE. INHIBITION	The converter interlock is active.	Alarm
MA806	INVERTER OVERLOAD	The inverter output current has exceeded 110% for 1 min. or 130% for 30sec. of the rated current.	Alarm Overload
MA807	INVERTER OVERLOAD	The inverter output current has exceeded 110% of the rated current.	Alarm Overload
MA810	INVERTER OVERLOAD	Short time over-current has exceeded 150% of the rated current	Alarm Overload
MA817	EMERGENCY STOP ACTIVATED	The emergency stop was activated by the EPO switch or an external contact.	Alarm
MA824	72B OPEN	The battery disconnect contactor 72B open.	Alarm
MA825	BATTERY ABNORMAL	Battery voltage is less than end voltage at startup.	Alarm
MA828	COOLING FAN ABNORMAL	Rotation sensor detect fan abnormal.	Alarm
MA834	BATTERY DEPLETED	The battery voltage has reached the depleted level.	Major End-of-Discharge
MA836	INVERTER OVERLOAD	The output load active power has exceeded 110% of the rated current.	Alarm Overload
MA866	UPS CONTROL CIRCUIT ERROR	Communication signal was lost from the bypass module.	Minor
MF001	INPUT CIRCUIT ABNORMAL	Detection of a large variation of the reference error signal.	Major
MF002	CONVERTER OVERCURRENT	Detection of converter overcurrent.	Major
MF003	PRECHARGE FAULT	Pre-charging circuit is not working properly.	Major
MF102	DC OVERVOLTAGE	DC voltage surpasses the overvoltage level.	Major
MF103	DC UNDERVOLTAGE	DC voltage dropped below the undervoltage level.	Major
MF104	DISCHARGE FAULT	Capacitor voltage is higher than 100V at 5 minutes after module stop.	Major
MF108	CHOPPER OVERCURRENT	Detection of DC overcurrent.	Major
MF109	DC UNBALANCED	Major unbalance of the neutral point voltage.	Major

Code indication (Note 2)	Status message	Meaning	External relay contact (Note 1)
MF112	DC CIRCUIT ABNORMAL	Sudden change of the DC voltage level.	Major
MF128	CONTROL POWER SUPPLY ABNORMAL	Power supply voltage to IGBT driver PCB is below the specified level.	Major
MF162	BATTERY ABNORMAL	Failure detection based on battery self-check.	Minor
MF163	BATTERY VOLTAGE ABNORMAL	Battery voltage is abnormal.	Minor
MF169	BATTERY VOLTAGE ABNORMAL	Battery voltage is abnormal.	Minor
MF170	VDB SENSOR ABNORMAL	Detection of a large variation of the difference between control-only and protection-only battery voltage.	Minor
MF201	INVERTER OVERVOLTAGE	Detection of output overvoltage.	Major
MF202	INVERTER UNDERVOLTAGE	Output voltage dropped.	Major
MF203	INVERTER OVERCURRENT	Detection of inverter overcurrent.	Major
MF204	OUTPUT CIRCUIT ABNORMAL	Detection of a large variation of the reference error signal (current reference and actual current).	Minor
MF206	UPS CONTROL CIRCUIT ERROR	Discrepancy between output voltage and external voltage (bypass, common ac bus)	Major
MF208	UPS CONTROL CIRCUIT ERROR	Cross current is abnormal.	Major
MF210	52C ABNORMAL	Error to open the contactor 52C.	Major
MF213	OVERTEMPERATURE	Heatsink temperature exceeds thermal settings.	Major
MF214	COOLING FAN ABNORMAL	Thermal relay activated protection.	Major
MF253	UPS CONTROL CIRCUIT ERROR	Discrepancy between output voltage and inverter voltage, or between output voltage and bypass voltage.	Minor
MF301	UPS CONTROL CIRCUIT ERROR	AD reference has an abnormal value.	Major
MF302	UPS CONTROL CIRCUIT ERROR	Detection of an external interruption during the software execution.	Major
MF303	UPS CONTROL CIRCUIT ERROR	Timer does not reset in the specified period (WDT settings)	Major
MF305	UPS CONTROL CIRCUIT ERROR	Detection of an abnormal clock speed in the DSP or FPGA.	Major
MF306	UPS CONTROL CIRCUIT ERROR	Control power supply voltage is below the specified level.	Major
MF309	INVERTER VOLTAGE ABNORMAL	Inverter voltage is out of the specified range.	Major
MF320	UPS CONTROL CIRCUIT ERROR	Cable disconnection in the parallel interface board during load supply.	Major

Code indication (Note 2)	Status message	Meaning	External relay contact (Note 1)
MF376	UPS CONTROL CIRCUIT ERROR	Logic signal abnormal (Supply ON)	Minor
MF552	DUMMY FAULT	Bypass Module send fault simulation signal.	Major

(Note 1) 1) "Major" is defined as a major failure. Load transferred from the inverter circuit to the static bypass line;

2) "Minor" is defined as a minor failure. UPS continues to operate normally, but the cause of alarm must be identified;

(Note 2) Code indication means:

#A+++ ----- Alarm  
#F+++ ----- Failure  
#%0++ ----- Rectifier circuit failure  
#%1++ ----- DC circuit failure  
#%2++ ----- Inverter circuit failure  
#%3++ ----- Control circuit failure  
#%4++ ----- Bypass system failure  
#%8++ ----- Alarm

"#" Bypass Module "U", Power Converter Module "M"

"+" denotes any numeral from 0 to 9

"%" denotes either "A" or "F"

## 7 WARRANTY & OUT OF WARRANTY SERVICE

The Mitsubishi Electric UPS Division Service Department has many Authorized Service Centers place strategically throughout the US, Canada and Latin America. For both in warranty and out of warranty service, please contact Mitsubishi Electric Power Products, Inc. at (724) 772-2555. To register your UPS for warranty purposes, please complete the warranty registration form and fax it to the Mitsubishi Electric UPS Division Service Department fax line shown on the registration form. (Next page)

For warranty purposes, it is essential that any and all service work that may be required on your Mitsubishi brand UPS equipment is performed by a Mitsubishi Electric Authorized Service Center. The use of non-authorized service providers may void your warranty.

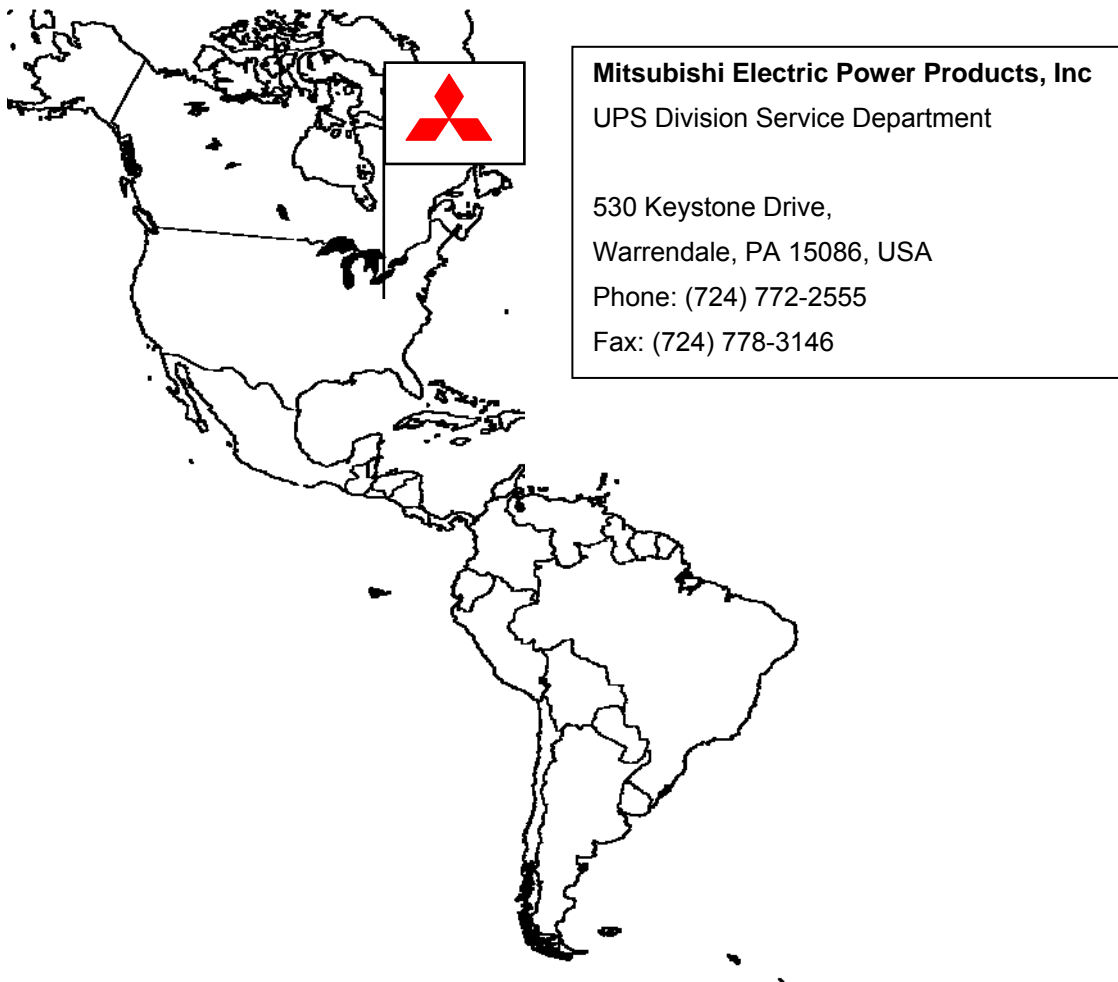



Mitsubishi Electric Power Products, Inc.  
UNINTERRUPTIBLE POWER SUPPLIES  
530 Keystone Drive, Warrendale, PA 15086 Phone: (724) 772-2555, Fax: (724) 778-3146

## UPS Warranty Registration

 Register UPS for Warranty

 Address Change

**To validate the Warranty on your UPS this form must be filled out completely by Customer and returned.**

CUSTOMER INFORMATION			
Your Name:		Job Title:	
Company Name:			
Division / Department:			
Address:			
City:		State:	Zip Code:
Country:		Province:	
Business Phone:	Ext:	Fax:	
E-Mail: _____ @ _____		Internet Address:	
UPS Model #:	Capacity (kVA):	UPS Serial #:	
Start-Up Date:     /     /	Authorized Mitsubishi Service Company (if known):		
Signature: _____		Date:     /     /	

**Which ONE of These Best Describes Your Organization's Primary Business Classification?**

- |  |  |
|--|--|
| <input type="checkbox"/> {Energy Producer}<br>___ Utility<br>___ Alternate Energy<br><input type="checkbox"/> {Manufacturing Co.}<br>___ OEM<br>___ Process<br>___ Consumer Goods<br>___ Electronics<br>___ Power Quality<br>___ Equipment<br><input type="checkbox"/> Commercial Business<br><input type="checkbox"/> Electrical Contractor<br><input type="checkbox"/> Healthcare<br><input type="checkbox"/> Internet | <input type="checkbox"/> Education/Univ. Service<br><input type="checkbox"/> {Service}<br>___ Consulting<br>___ Engineering<br>___ Outsourcing<br>___ Financial/Legal/Insurance<br><input type="checkbox"/> {Government}<br>___ Military<br>___ Municipals<br>___ Federal/State/Local<br><input type="checkbox"/> Communications<br><input type="checkbox"/> Distributors/Reps<br><input type="checkbox"/> Other _____ |
|--|--|

**Number of Employees at This Location is:**

- |             |               |                  |
|-------------|---------------|------------------|
| ___ 1 – 19  | ___ 100 – 249 | ___ 1000 or more |
| ___ 20 – 49 | ___ 250 – 499 |                  |
| ___ 50 – 99 | ___ 500 – 999 |                  |

**Overall how was Start-Up performed:**

- \_\_\_ Unsatisfactory  
 \_\_\_ Satisfactory  
 \_\_\_ Exceeded Expectations

**Would you like to receive future product updates and news?**

- \_\_\_ Yes     \_\_\_ No

**After Start-Up has been done Fax completed Form to:  
(724) 778-3146**

