

**MITSUBISHI
ELECTRIC**

UNINTERRUPTIBLE POWER SUPPLY SYSTEM

MODEL

9900A SERIES

OWNERS / TECHNICAL MANUAL

(Inclusive Parallel Operation System Application)

Preface

Revision 1.2 December 3, 08
ALN-H1844

TABLE OF CONTENTS

LIST OF TABLES	ii
LIST OF FIGURES	iii
HOW TO USE THIS MANUAL	iv
1.0 INTRODUCTION	1-1
1.1 SAFETY PRECAUTION	1-2
1.2 GENERAL	1-5
1.3 DEFINITIONS	1-6
1.4 OPERATION OVERVIEW	1-7
1.5 SPECIFICATIONS	1-16
2.0 OPERATION CONTROLS AND INDICATORS	2-1
2.1 LED DISPLAY	2-2
2.2 EPO BUTTON	2-2
2.3 LIQUID CRYSTAL DISPLAY	2-3
2.4 EXTERNAL SIGNAL TERMINAL BLOCK	2-10
2.5 EXTERNAL COMMUNICATION CONNECTOR	2-15
3.0 INSTALLATION AND OPERATION	3-1
3.1 TRANSPORTATION AND INSTALLATION	3-1
3.2 INSTALLATION PROCEDURE	3-1
3.3 PROCEDURE FOR CABLE CONNECTIONS	3-2
3.4 OPERATING PROCEDURES	3-11
4.0 RESPONSE TO UPS FAILURE	4-1
5.0 PARTS REPLACEMENT	5-1
6.0 FAULT CODES	6-1
7.0 WARRANTY & OUT OF WARRANTY SERVICE	7-1

LIST OF TABLES

Table 1.1	UPS Installation Environment.....	1-3
Table 1.2	Rating of Bypass Input Circuit Breaker	1-4
Table 1.3	Power Specifications.....	1-16
Table 1.4	UPS Module Information.....	1-16
Table 1.5	Detail of Specifications.....	1-17
Table 1.6	Rating of Contactors, Breakers and Fuses.....	1-18
Table 3.1	How to Transport and Install the System.....	3-1
Table 3.2	List of UPS Weights (lb.).....	3-1
Table 3.3	Maximum Permitted Fault Current.....	3-2
Table 3.4	Recommended Cable Sizes	3-5
Table 3.5	Crimp Type Compression Lug.....	3-6
Table 6.1	Fault Code.....	6-2

LIST OF FIGURES

Figure 1.1	Single Line Diagram-Normal Operation.....	1-7
Figure 1.2	Single Line Diagram-Bypass Operation	1-8
Figure 1.3	Single Line Diagram-Battery Operation.....	1-9
Figure 1.4	UPS Parts Location.....	1-11
Figure 1.5	Display PCB DPAU-81.....	1-12
Figure 1.6	External I/F PCB IOAU-09	1-12
Figure 1.7	Parallel I/F PCB IFAU-08	1-13
Figure 1.8	MAIN PCB UPGR-M	1-13
Figure 2.1	Operation/Display Panel	2-1
Figure 2.2	Main Screen	2-3
Figure 2.3-a	Startup/Shutdown guidance.....	2-4
Figure 2.3-b	Startup guidance.....	2-4
Figure 2.3-c	Shutdown guidance	2-4
Figure 2.4-a	Input values.....	2-5
Figure 2.4-b	Output values.....	2-5
Figure 2.4-c	Values battery operation.....	2-5
Figure 2.5-a	Remote/Local operation select	2-6
Figure 2.5-b	Date & Time adjustment	2-6
Figure 2.6-a	Log menu	2-7
Figure 2.6-b	Event log	2-7
Figure 2.6-c	Battery log	2-7
Figure 2.7-a	Main Screen (Battery Operation)	2-8
Figure 2.7-b	Measurement Screen (Battery Operation).....	2-8
Figure 2.8	Main Screen (Fault Indication).....	2-8
Figure 2.9	Message Screen	2-9
Figure 2.10-a	External Signal Terminal Block (TN2)	2-10
Figure 2.10-b	External Signal Terminal Block (TN1)	2-11
Figure 2.11	Control Wiring for External Contacts	2-12
Figure 2.12	Remote "Start" Contact Connections	2-13
Figure 2.13	External communication connector	2-15
Figure 3.1	UPS Terminal Designation	3-6
Figure 3.2	Diagram of input/output bus bars and terminal blocks	3-7
Figure 3.3	Diagram of Power wire & Control wire Inter-connect between UPS and Battery	3-8
Figure 3.4	Diagram of Power wire Connect (Parallel Connection).....	3-9
Figure 3.5	Diagram of Power and Control wire Connect (Parallel Connection)	3-10

HOW TO USE THIS MANUAL

This manual is designed for ease of use, giving the user easy and quick reference to information.

This manual uses notice icons to draw attention to the user important information regarding the safe operation and installation of the UPS. The notice icons used in this manual are explained below, and should be taken into account and adhered to whenever they appear in the text of this manual.



Warning: A warning notice icon conveys information provided to protect the user and service personnel against hazards and/or possible equipment damage.



Caution: A caution notice icon conveys information provided to protect the user and service personnel against possible equipment damage.



Note: A Note notice icon indicates when the user should make a reference of information regarding the UPS operation, load status and display status. Such information is essential if Mitsubishi field service group assistance and correspondence is required.

Safety Recommendations: If any problems are encountered while following this manual, Mitsubishi field service group assistance and correspondence is recommended.

1.0 INTRODUCTION

The Mitsubishi Uninterruptible Power Supply System (UPS) is designed to provide many years of reliable protection from power failure, brown-outs, line noise, and voltage transients. To ensure optimum performance of the equipment, follow the manufacturer's instructions. This manual contains descriptions required to operate the UPS. Please read this manual carefully and retain it for future reference.

IMPORTANT SAFETY INSTRUCTIONS
SAVE THESE INSTRUCTIONS



This manual contains important instructions for the 9900A SERIES Uninterruptible Power Supply Systems that should be followed during installation and maintenance of the UPS and batteries.

WARNING 1



Lethal voltages exist within the equipment during operation. Observe all warning and cautions in this manual. Failure to comply may result in serious injury or death. Obtain qualified service for this equipment as instructed.

WARNING 2

In no event will MITSUBISHI be responsible or liable for either indirect or consequential damage or injury that may come from the use of this equipment.

Any modifications without authorization by MITSUBISHI could result in personal injuries, death or destruction of the UPS.

1.1 SAFETY PRECAUTIONS

APPLICATION

This UPS shall NOT be applied to support equipment (*) that could affect the human lives.

- *
 - Medical operation room equipment
 - Life support equipment (artificial dialysis, incubators, etc.)
 - Toxic gas or smoke eliminators
 - Equipment that must be provided under fire laws, construction standards or other ordinances
 - Equipment equivalent to the above

Special considerations are required when applying this UPS to the equipment () that affect human safety and/or maintain public services**

- **
 - Equipment to supervise or control airways, railways, roads, sea-lanes or other transportation.
 - Equipment in nuclear power plants.
 - Equipment to control communications.
 - Equipment equivalent/similar to the above mentioned.

WARNING 3


The UPS is to be installed in a controlled environment.

Improper storage and installation environment may deteriorate insulation, shorten component life and cause malfunctions.

Keep the installation environment per standard described as follows:

TABLE 1.1 UPS Installation Environment

No.	Item	Environment standard	
1	Installation location	Indoors	
2	Ambient temperature	Minimum temperature: 32°F(0°C), Maximum temperature: 104°F(40°C) The average temperature over any 24-hour period must be in the range 41° F (5°C) to 95°F(35°C).	
3	Relative humidity	The relative humidity must be held between 5 and 95%. There must be no condensation due to temperature changes.	
4	Altitude	This equipment must not be applied at altitude that exceeds 2250m(7400ft) above seal level.	
5	Dust	Dust in the room where the UPS is installed must not exceed normal atmospheric dust levels. In particular, that dust should not include iron particles, oils or fats, or organic materials such as silicone.	
6	Inflammable gas following IEC654-4 Part 4	There should be no inflammable/explosive gas.	
		Hydrogen sulfide (H ₂ S)	No more than 0.003 PPM
		Sulfurous acid gas (SO ₂)	No more than 0.01 PPM
		Chlorine gas (Cl ₂)	No more than 0.002 PPM
		Ammonia gas (NH ₃)	No more than 1 PPM
		Nitrous oxides (NO _x)	No more than 0.05 PPM
	Ozone (O ₃)	No more than 0.002 PPM	

WARNING 4

This UPS does not include a Bypass input circuit breaker (MCCB) to protect bypass circuit. The Bypass input circuit breaker (MCCB) is to be field supplied and installed. Recommended Breaker (MCCB)'s Specifications are as follows:

TABLE 1.2 Rating of Bypass Input Circuit Breaker

Capacity (kVA)	Bypass Voltage (Vac)	Bypass Rating (Aac)	Breaker (A)
80	480	96	125
100	480	120	150
150	480	180	225
225	480	271	350

AC input and AC output overcurrent protection and disconnect devices shall be field supplied and installed. The DC circuit breaker (MCCB) shall be field supplied and installed. The overcurrent protection device should be installed in the Battery cabinet and rated as indicated in TABLE 1.6.

Note: The DC input overcurrent protection (Battery disconnect breaker) hereinafter will be referred as “CB2”.

1.2 GENERAL

The Mitsubishi 9900A SERIES UPS is designed to provide continuous and clean electrical power to a critical load. Additionally the UPS monitors power conditions affecting the load. In the event of an input power failure, the UPS will supply power to the critical load for the specified battery time.

If the input power is not restored promptly, back up power from the UPS battery permits the orderly shutdown of equipment supported by the UPS. The UPS is simple to start-up, operate and maintain.

The 9900A SERIES UPS is available in Four kVA sizes - 80, 100, 150 and 225kVA. Specifications for each kVA model appear in Section 1.5. The principles of operation described herein are applicable to all models.

This manual provides an overview of the 9900A SERIES components and their functions. The appearance and purpose of operator controls and indicators is described with procedures for operation, start-up, shutdown and basic maintenance included.

1.3 DEFINITIONS

UNINTERRUPTIBLE POWER SUPPLY SYSTEM (UPS) - All components within the UPS Module Cabinet and associated batteries that function as a system to provide continuous, conditioned AC power to a load. This is sometimes referred to as the "System".

UPS MODULE CABINET - The metal enclosure which contains the Converter / Charger, Inverter, Static Transfer Switch, Internal Bypass line, operator controls, and internal control systems required to provide specified AC power to a load.

UPS MODULE - The Converter / Charger and Inverter assemblies which, under the direction of the internal control system and operator controls, provide specified AC power to a load.

INVERTER - The UPS components which contain the equipment and controls necessary to convert DC power from the Converter / Charger, or the battery, to AC power required by the critical load.

CONVERTER / CHARGER - The UPS components which contain the equipment and controls necessary to convert input AC power to regulated DC power required for battery charging and for supplying power to the Inverter.

STATIC TRANSFER SWITCH - The device which connects the critical load to the bypass line when the Inverter cannot supply continuous power.

BYPASS LINE - The line which conducts electricity directly from the input power source to the critical load during Maintenance or whenever the UPS is not completely operational.

AC INPUT POWER - Power provided by the electrical utility company, or auxiliary generator, which is connected to the UPS for supplying the critical load.

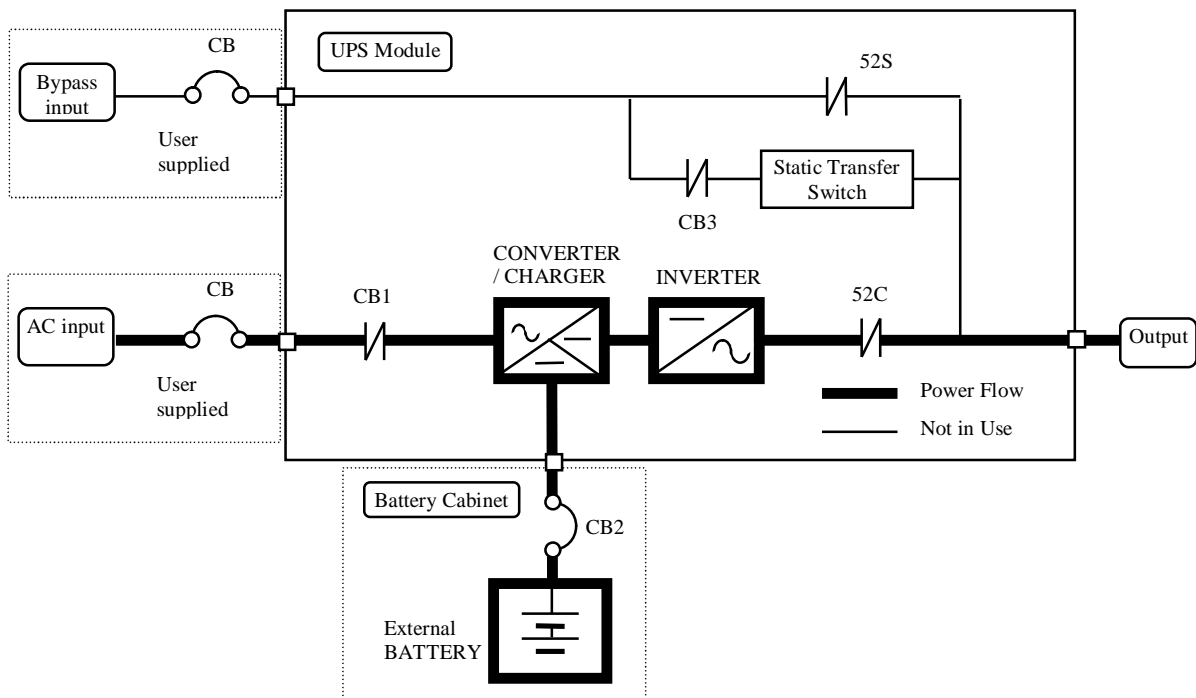
BATTERY - The rechargeable battery strings which supply DC power to the inverter to maintain continuous AC power to the load during AC input power failure conditions.

1.4 OPERATION OVERVIEW

The UPS provides two power paths between the utility source and the critical load. Figure 1.1 shows the path for normal operation, with the load powered from the inverter. Figure 1.2 shows the path for bypass operation, with the load supplied through the static bypass line.

A) Normal operation: Load power supplied by each system UPS inverter.

Figure 1.1 Single Line Diagram - Normal Operation: Load powered by UPS inverter



During normal operation, the path through the UPS inverters is used to power the load.

Referring to Figure 1.1: Input AC power is converted to DC by the Converter. DC power is utilized to charge the UPS battery and to provide power to the Inverter. The Inverter converts the DC power to clean AC power to supply the critical load.

The conversion - inversion process eliminates any voltage transients or fluctuations existing in the input power before it reaches the critical load.

The power drawn by the critical load is equally shared between all UPS whenever the system is in the Parallel Operation. (Refer to Figure 3.4 that shows a sample of Parallel Operation System Configuration.)

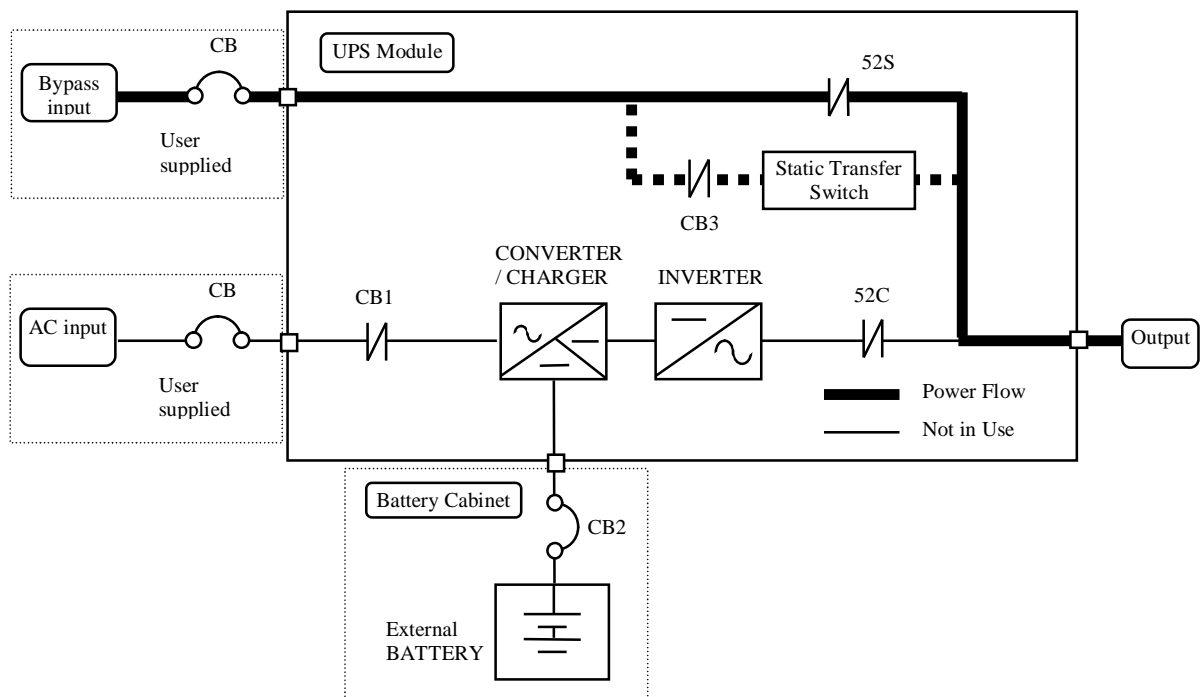
In the event of a UPS module failure during Parallel Operation, the critical load power will be continually supplied and shared by all other UPS.



The Bypass Input circuit breaker (MCCB) for protection of the UPS and cables are field supplied and field installed. (See WARNING 4 on page 1-4)

B) Bypass Operation: Load Power supplied through UPS internal static bypass line.

FIGURE 1.2 Single Line Diagram - Bypass Operation: Load fed through static bypass line.



Referring to Figure 1.2: The Internal Bypass line is a Hard-wired line through 52S which supplies the critical load with unconditioned bypass input power. Upon switching to the Internal Bypass line, the Static Transfer Switch line through CB3 (herein after STS contactor CB3) supplies the power immediately, and then the Internal Bypass line through 52S supplies the power. In the event of a switching to the Bypass line, the power to the critical load will be uninterrupted. The purpose of this Internal Bypass line is to route power to the critical load while the UPS module is de-energized (converter and inverter), and during Start-up before the system is fully operational.

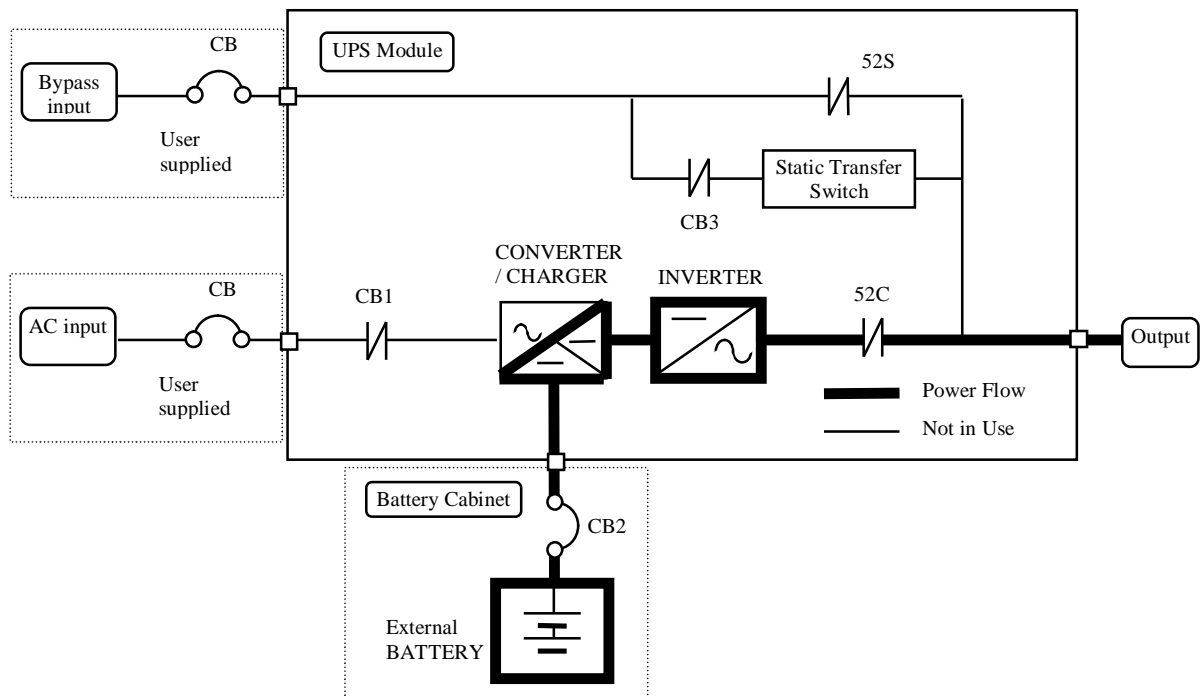
Each UPS internal static bypass line will equally share the power supplied to the critical load whenever the system is in the Parallel Operation.

In the event of a load overcurrent, the UPS transfers to bypass without interruption to the critical load. In the case of the Parallel Operation, all UPS will transfer to bypass without interruption to the critical load.

The internal control system determines the operation of the two paths, with the load powered from the inverter being the normal operation.

C) Battery operation: Load Power supplied by UPS battery.

FIGURE 1.3 Single Line Diagram - Battery Operation



Referring to Figure 1.3: In the event of AC input source failure or interruption, the UPS Converter(s)* will de-energize and the UPS battery(s)* will immediately discharge and supply DC power to the Inverter to maintain continuous AC power to the load. This operation will continue until:

- a) The battery capacity expires and the inverter turns off, or
- b) Input power is restored after which the converter will power the inverter and critical load and simultaneously recharge the batteries.

A fully charged battery will provide power for the specified time at the rated load, or longer, at a reduced load.

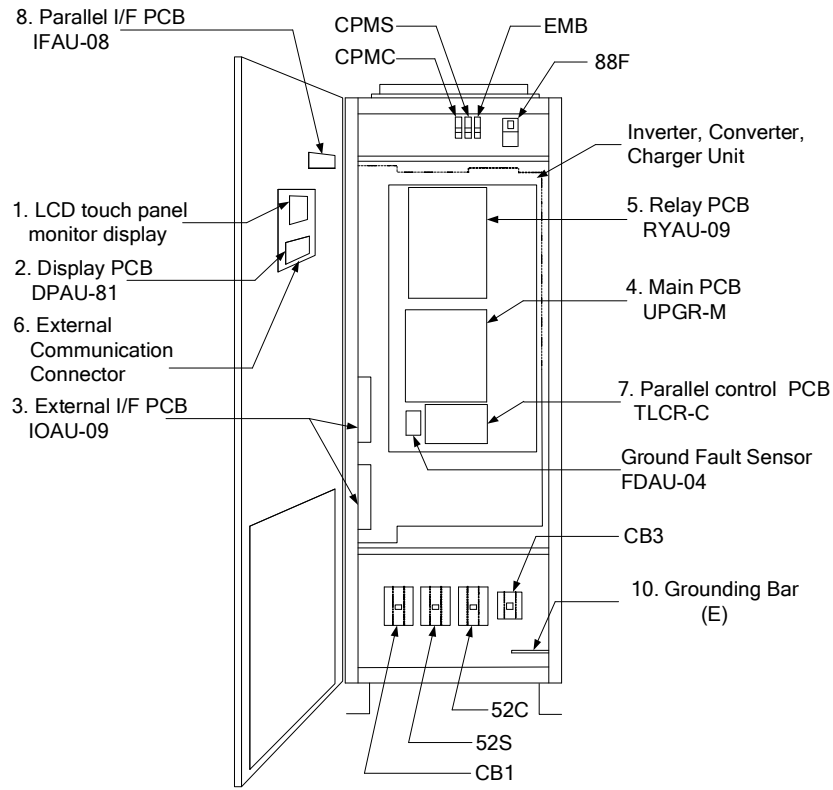
(s)* : In the case of the Parallel Operation

When power is restored after a low battery shutdown, the UPS converter(s)* automatically restarts operation, the charger(s)* recharges the batteries and the Inverter(s)* is automatically restarted without operator intervention. Load is automatically assumed by the inverter without operator intervention.

(s)* : In the case of the Parallel Operation

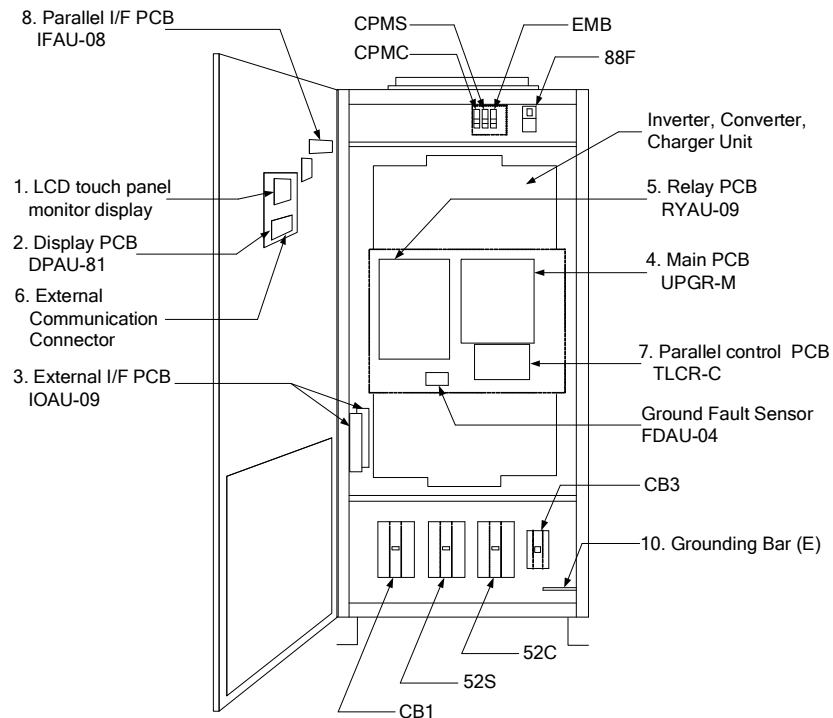
The power drawn by the load is equally shared between all UPS regardless of the presence or absence of the UPS that is (are) in battery operation or not whenever the system is in the Parallel Operation. .

FIGURE 1.4-a UPS Parts Location (80/100kVA)
UPS module Front View



* Item 9 (AC input, AC output, DC input terminal) is not shown in Figure 1.4-a. (Refer to Figure 3.2)

FIGURE 1.4-b UPS Parts Location (150, 225kVA)
UPS module Front View



* Item 9 (AC input, AC output, DC input terminal) is not shown in Figure 1.4-b. (Refer to Figure 3.2)

FIGURE 1.5 Display PCB DPAU-81

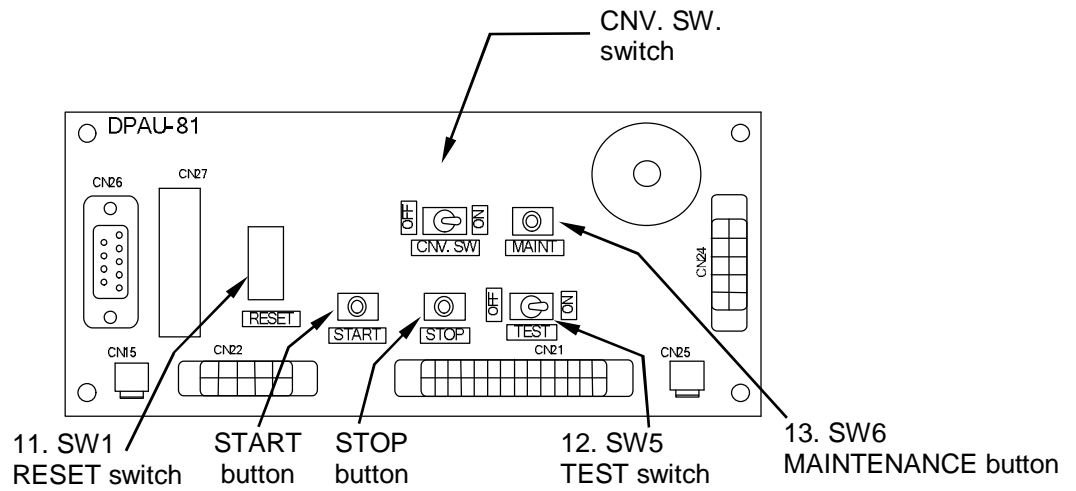


FIGURE 1.6 External I/F PCB IOAU-09

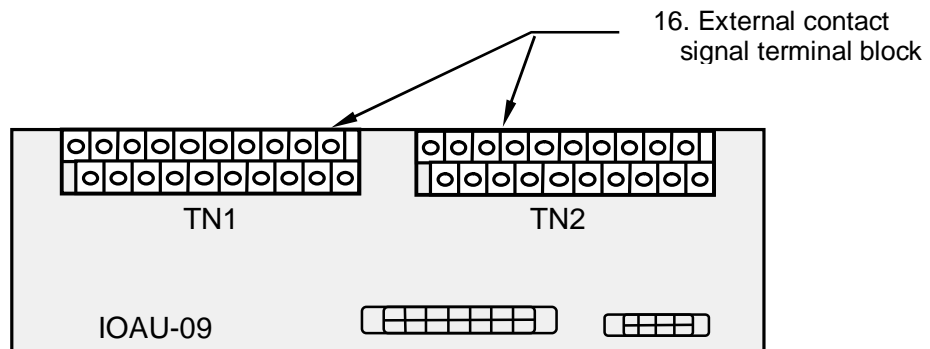


FIGURE 1.7 Parallel I/F PCB IFAU-08

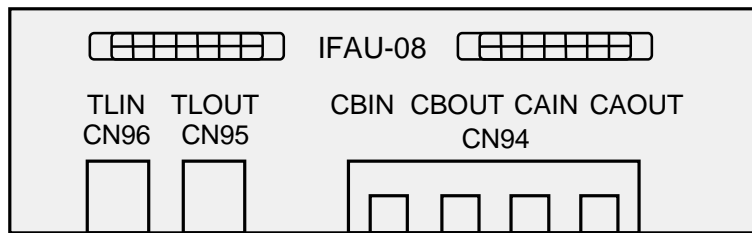
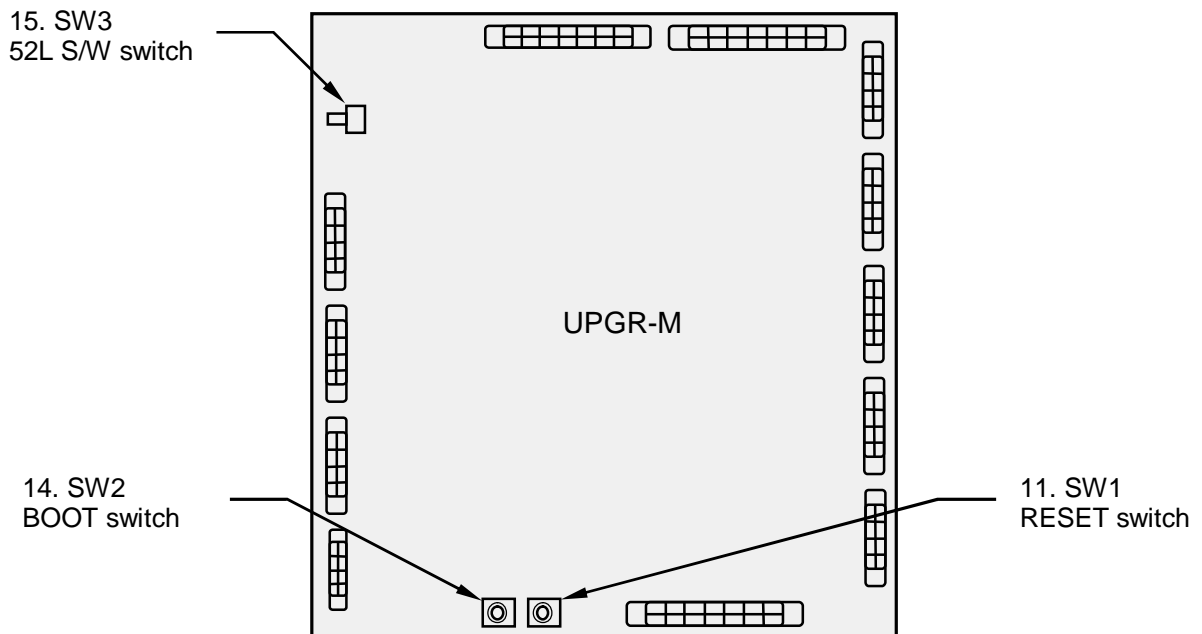


FIGURE 1.8 MAIN PCB UPGR-M



Description of Figures 1.4 to 1.8:

1. **LCD Touch Panel Monitor Display**

The Liquid Crystal Display (LCD) Touch Panel Monitor Display indicates power flow, measured values and fault and error messages via user selectable display screens.

Refer to FIGURE 2.1 for details.

2. **Display PCB DPAU-81** (Figure 1.5):

Switches on DPAU-81 board : FOR SERVICE PERSONNEL ONLY

- (11) SW1 (RESET switch)
- (12) SW5 (TEST switch)
- (13) SW6 (MAINTENANCE switch)

3. **External I/F PCB IOAU-09** (Figure 1.6):

Signal I/F on IOAU-09 board

- (16) External contact signal terminal block

Refer to FIGURE 2.10 for details.

4. **Main PCB UPGR-M** (Figure 1.8):

Switches on UPGR-M board : FOR SERVICE PERSONNEL ONLY

- (11) SW1 (RESET switch)
- (14) SW2 (BOOT switch)
- (15) SW3 (52L S/W switch)

5. **Relay PCB RYAU-09**

6. **External Communication Connector**

RS232C connector on DPAU-81 board : FOR SERVICE PERSONNEL ONLY

Refer to FIGURE 2.13 for details.

7. **Parallel control PCB TLCR-C**

For use in Parallel Operation system application : Option

8. **Parallel I/F PCB IFAU-08**

For use in Parallel Operation system application : Option (Figure 1.7):

Refer to FIGURE 3.5 for details.

9. **AC input, AC output, DC input terminal**

Refer to Figure 3.2 for details

10. **Grounding Bar (E)**

11. **"RESET" switch (FOR SERVICE PERSONNEL ONLY)**
This switch resets errors resulting from alarm conditions.
12. **"TEST" switch (FOR SERVICE PERSONNEL ONLY)**
This switch changes system operation to the test-mode.
13. **"MAINTENANCE" switch (FOR SERVICE PERSONNEL ONLY)**
This switch sets the UPS menu parameters.
14. **"BOOT" switch (FOR SERVICE PERSONNEL ONLY)**
This switch boots the processor on the main control circuit board following alarm conditions.
15. **"52L S/W" switch (FOR SERVICE PERSONNEL ONLY)**
This switch prohibits turning on the AC output contactor "52C" during test/maintenance in Parallel Operation system application.
16. **External contact signal terminal block**
Terminal block to connect contact signal input/output lines to and from external dry contacts.
Refer to FIGURE 2.10 for details.

1.5 SPECIFICATIONS

The UPS nameplate displays the rated kVA as well as nominal voltages and currents. The nameplate is located on the inside of the UPS front door.

TABLE 1.3 Power Specifications

Rated output Power	Input voltage 3 phase / 3 wire	Bypass input voltage 3 phase / 3 wire	Output voltage 3 phase / 3 wire
80kVA / 72kW	480V	480V	480V
100kVA / 90 kW	480V	480V	480V
150kVA / 135kW	480V	480V	480V
225kVA / 202.5kW	480V	480V	480V

TABLE 1.4 UPS Module Information

UPS [kVA]	Cable Entry	Width [in / mm]	Depth [in / mm]	Height [in / mm]	Weight [lb./ kg]	Heating [kBTH / h]
80	BOTTOM	27.6 / 700	32.8 / 832	80.6 / 2047	855 / 388	11.3
100	BOTTOM	27.6 / 700	32.8 / 832	80.6 / 2047	855 / 388	14.1
150	BOTTOM	35.4 / 900	32.8 / 832	80.6 / 2047	1160 / 526	18.2
225	BOTTOM	35.4 / 900	32.8 / 832	80.6 / 2047	1230 / 558	27.3

TABLE 1.5 Detail of Specifications

Rated Output kVA	80	100	150	225
Rated Output kW	72	90	135	202.5
AC INPUT				
Configuration	3 phase, 3 wire			
Voltage	480 V +15% to -20%			
Frequency	60 Hz +/-10%			
Reflected Current THD	3% at 100% load (no input filter required)			
STATIC BYPASS INPUT				
Configuration	3 phase, 3 wire			
Voltage	480 V +/-10%			
Frequency	60 Hz +/-5%			
BATTERY				
Type	Lead Acid			
Ride Through	Application Specific			
Nominal Voltage	480 Vdc			
Minimum Voltage	400 Vdc			
Number of Cells	240			
AC OUTPUT				
Configuration	3 phase, 3 wire			
Voltage	480 V			
Voltage Regulation	+/-1%			
Frequency	60 Hz			
Frequency Regulation	+/-0.01 in free running mode			
Power Factor	0.9 nominal			
Power Factor Range	0.9 to 1.0 lagging (within output kW rating)			
Voltage THD	2% maximum THD at 100% Linear Load 5% maximum THD at 100% non-linear load			
Transient Response	+/-2% maximum at 100% load step +/-1% maximum at loss/return of AC power +/-5% maximum at load transfer to/from static bypass			
Transient Recovery	Less than 20ms			
Voltage Unbalance	1% maximum at 100% unbalanced load			
Phase Displacement	1 deg. maximum at 100% load			
Inverter Overload	125% for 2 minutes; 150% for 60 seconds			
Bypass Overload	1000% for 1 cycle (with bypass available)			
Withstand Rating	65kA* * : with optional fuse			
ENVIRONMENTAL				
Cooling	Forced Air			
Operating Temperature	32° F to 104° F (0° C to 40° C). Recommended : 68° F to 86° F (20° C to 30° C)			
Relative Humidity	5% ~ 95% Non Condensing			
Altitude	0 to 7400 feet No Derating at 40° C			
Location	Indoor (free from corrosive gases and dust)			
Paint Color	Munsell 5Y7/1 (Beige)			

TABLE 1.6 Rating of Contactors, Breaker and Fuses

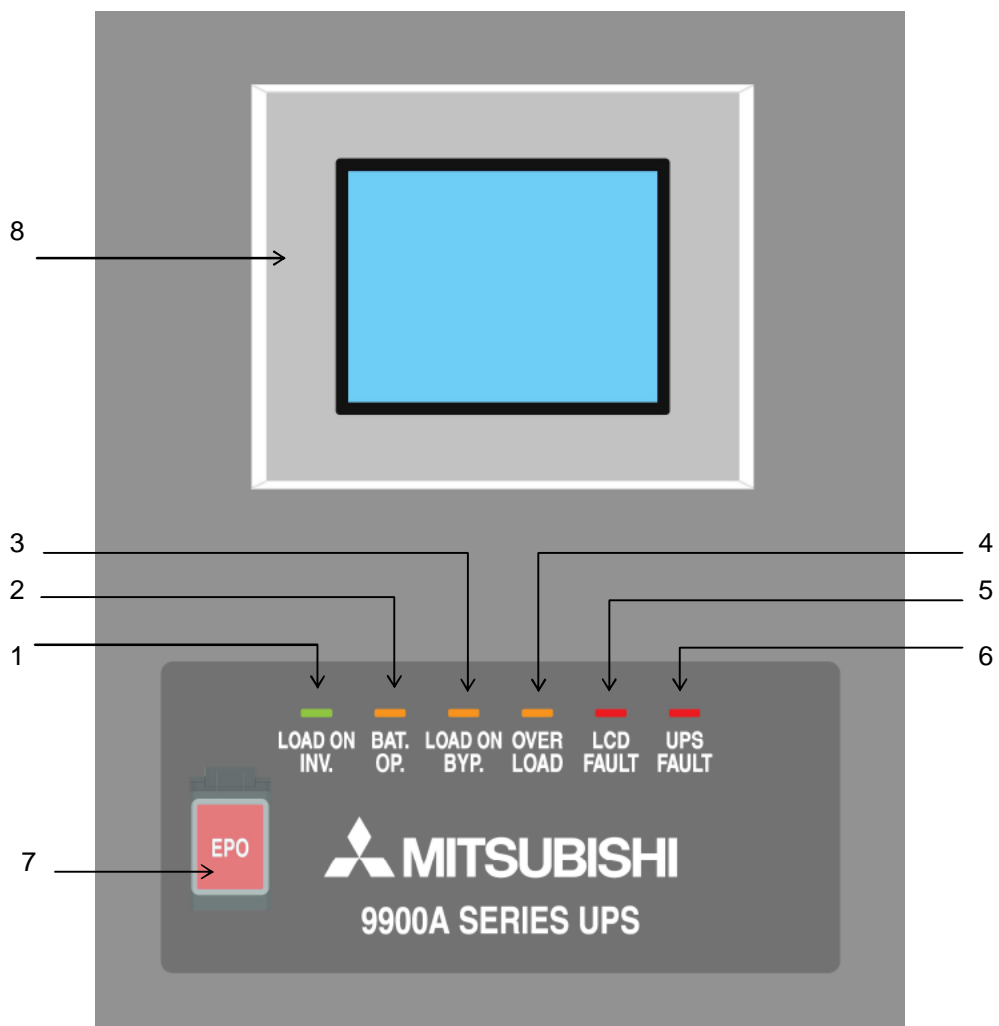
	NUMBER	APPLICATION	OUTPUT CAPACITY OF EQUIPMENT			
			80kVA	100kVA	150kVA	225kVA
			72kW	90kW	135kW	202.5kW
Contactor	CB1	AC input contactor	135A	135A	200A	285A
	CB3	STS contactor	80A	80A	135A	150A
	52C	Inverter output contactor	135A	135A	200A	285A
	52S	Bypass contactor	135A	135A	200A	285A
	88RC	Control circuit contactor	20A	20A	20A	20A
Breaker	CB2	Battery disconnect breaker (Recommended)	225A	300A	400A	600A
	User supply	AC input breaker (Recommended)	125A	150A	225A	350A
	User supply	AC output breaker (Recommended)	125A	150A	225A	350A
Fuses	FCU, FCV, FCW FCR, FCS, FCT	DC fuse	315A / 690V	315A / 690V	200A / 690V	200A / 690V
	FPU, FPV FNU, FNV	DC fuse	200A / 690V	200A / 690V	350A / 690V	350A / 690V
	FUA, FUB, FUC	Control power fuse	30A / 600V	30A / 600V	30A / 600V	30A / 600V
	(OPTION) FSU, FSV, FSW	Bypass input fuse	250A / 690V	250A / 690V	200A / 690V	250A / 690V
	FZS1, 2, 3	Bypass input ZNR fuse	5A / 500V	5A / 500V	5A / 500V	5A / 500V
	FBS1, 2, 3	Control power fuse	30A / 600V	30A / 600V	30A / 600V	30A / 600V
	FZR1, 2, 3	AC input ZNR fuse	5A / 500V	5A / 500V	5A / 500V	5A / 500V
	FEA, FEB, FEC	Parallel control circuit fuse	3A / 600V	3A / 600V	3A / 600V	3A / 600V

**Rating would be changed.*

2.0 OPERATOR CONTROLS AND INDICATORS

The 9900A Series operator controls and indicators are located as follows (Door exterior) :

FIGURE 2.1 Operation/Display Panel (Front panel)



2.1 LED DISPLAY

1) **Load on inverter [LOAD ON INVERTER](green)**

Illuminates when power is supplied from inverter to the critical load.
(Indicates the state of inverter transfer switch "52C".)

2) **Battery operation [BATTERY OP.](orange)**

Illuminates when power is supplied from batteries following a power failure.

3) **Load on bypass [LOAD ON BYPASS](orange)**

Illuminates when power is supplied to load devices by static bypass.
(Indicates the state of bypass transfer switch "52S".)

4) **Overload [OVERLOAD](orange)**

Illuminates in overload condition.

5) **LCD fault [LCD FAULT](red)**

Illuminates when an error occurs.

6) **UPS fault [UPS FAULT](red) [Annunciator: intermittent or constant tones]**

Illuminates when an error occurs in the system. In this case, the details of the error are indicated on the display panel.

2.2 EPO BUTTON (Emergency Power Off button) (7)

When activated, the Emergency Power Off (EPO) function shuts down the UPS module. The critical load will lose power and also shutdown. The EPO function can be performed both locally or remotely.

2.3 LIQUID CRYSTAL DISPLAY (8)

The Liquid Crystal Display (LCD) touch panel indicates power flow, measured values, operational guidance, data records and error messages. The LCD panel has a back-light which facilitates viewing in different ambient lighting conditions. The LCD will automatically clear and turn off, if the screen is not activated within 3 minute period. The LCD is turned back on when it is touched again. The ERROR indicator is cleared after 24 hours and can be reproduced by pressing any key on the panel.

2.3.1 MENU

A) MAIN MENU (FIGURE 2.2)

The LCD panel indicates power flow and measured values, while also operating the start/stop function. The LCD panel also allows the user to verify the status and operation of the UPS Module.

FIGURE 2.2 Main screen



The following will be displayed when the START/STOP key on the MAIN MENU is pressed (Jump into **OPERATION MENU**) :

1) Startup/Shutdown Guidance (FIGURE 2.3)

The display indicates the Startup and Shutdown guidance for the UPS system. If this operation is PIN protected, the user is required to enter the security PIN before the screen can be accessed.

When in remote mode, the message “REMOTE operating model” will appear on this Screen. The user cannot operate the start and stop functions without changing the setup from remote mode to local mode.

When bypass voltage is abnormal, the message “Bypass voltage abnormal” will appear.

- Start:** When the bypass voltage is abnormal, the LCD asks the operator if an interrupted transfer is acceptable (Load may be lost).
- Stop:** When the bypass voltage is abnormal, the user cannot transfer from inverter to bypass line.

FIGURE 2.3-a Startup/Shutdown guidance



FIGURE 2.3-b Startup guidance



FIGURE 2.3-c Shutdown guidance



Follow Startup/Shutdown guidance accordingly.

B) MEASUREMENT MENU (FIGURE 2.4)

This screen shows details of measured values. Input and Output values are displayed.

During Battery operation, Remaining battery power and Run time are also displayed.

FIGURE 2.4-a Input values



FIGURE 2.4-b Output values

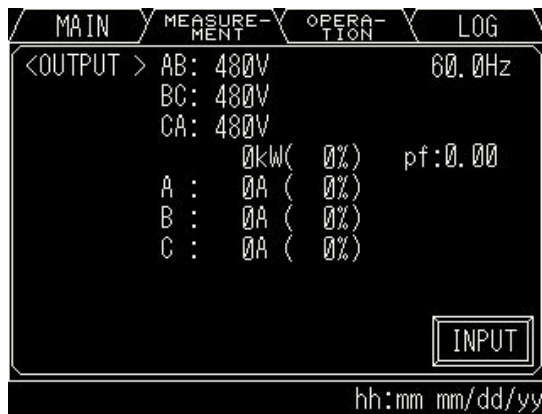
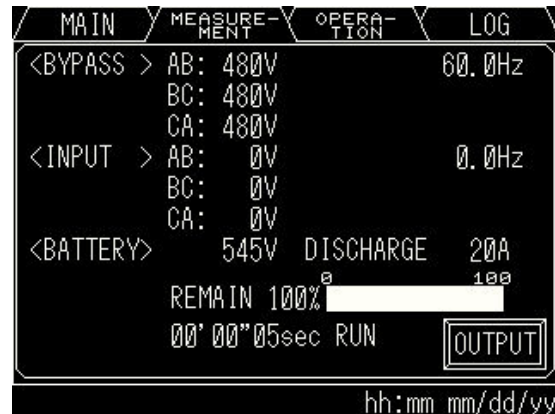


FIGURE 2.4-c Values in Battery operation



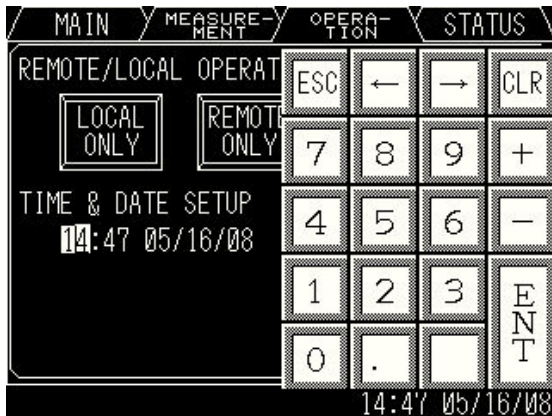
C) OPERATION MENU (FIGURE 2.5)

This screen prompts the user to select: (a) whether the start & stop operation will be performed by local or remote operation; (b) date & time adjustment; (c) battery equalizing charge. The battery equalizing charge operation key will appear when battery equalizing charge is set up (Setup is based on battery type).

FIGURE 2.5-a Remote/Local operation select



FIGURE 2.5-b Date & Time adjustment



D) LOG MENU (FIGURE 2.6)

This LOG MENU displays two Touch icons in EVENT LOG and BATTERY LOG. Pressing the EVENT LOG icon, up to 50 condition/operation records will be displayed. Press ▲ or ▼ button for page turning.

Pressing the BATTERY LOG icon, Number of battery operations and Summed battery operation time are displayed.

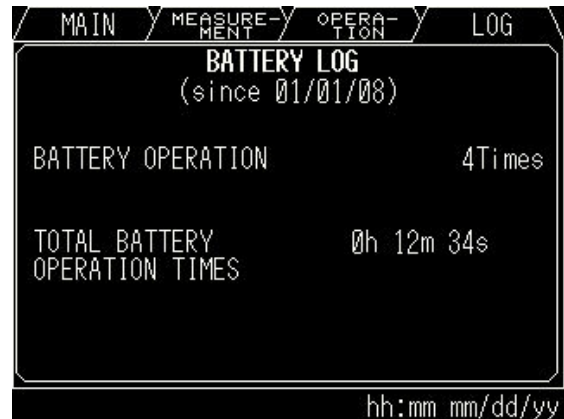
FIGURE 2.6-a Log menu



FIGURE 2.6-b Event log



FIGURE 2.6-c Battery log



2.3.2 INPUT POWER FAILURE (FIGURE 2.7)

During an Input Power Failure, the UPS inverter will be powered by the UPS batteries. The following will be displayed on the main and measurement screen (Indication of battery operation and remaining battery life).

FIGURE 2.7-a Main screen (Battery operation)



FIGURE 2.7-b Measurement screen (Battery operation)



The LCD will display a battery low voltage message when the battery capacity is near depletion. The End of Battery Discharge announcement is displayed when the battery end voltage is reached. At this time, the inverter will perform an electronic shutdown to prevent battery loss of life typical from extreme deep discharge conditions. When the input power is restored, the inverter will automatically restart to power the load, and the batteries will be simultaneously recharged. The End of Battery announcement is shown at the bottom of the screen.

2.3.3 FAULT INDICATION (FIGURE 2.8)

" MESSAGE " and " SILENCE ALARM " icons will appear on the main menu when UPS failure condition has occurred.

FIGURE 2.8 Main screen (Fault indication)

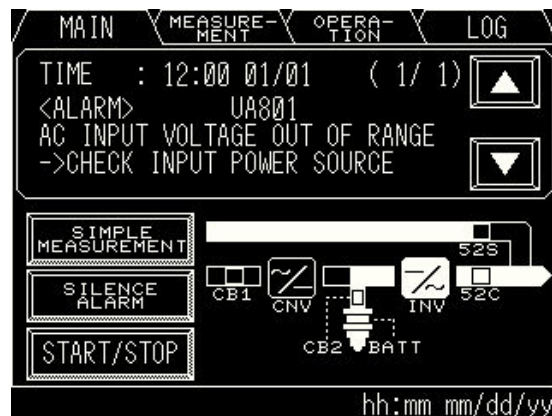


The following will be displayed when the MESSAGE icon on the main menu is pressed.

1) MESSAGE (FIGURE 2.9)

The display shows a fault code, the description of the fault and a guidance of what action is to be taken by the user. A maximum of 10 faults is displayed at one time. If an input power failure occurs during a fault condition, the fault indication and input power failure announcement are alternatively displayed at 5 second intervals.

FIGURE 2.9 Message screen



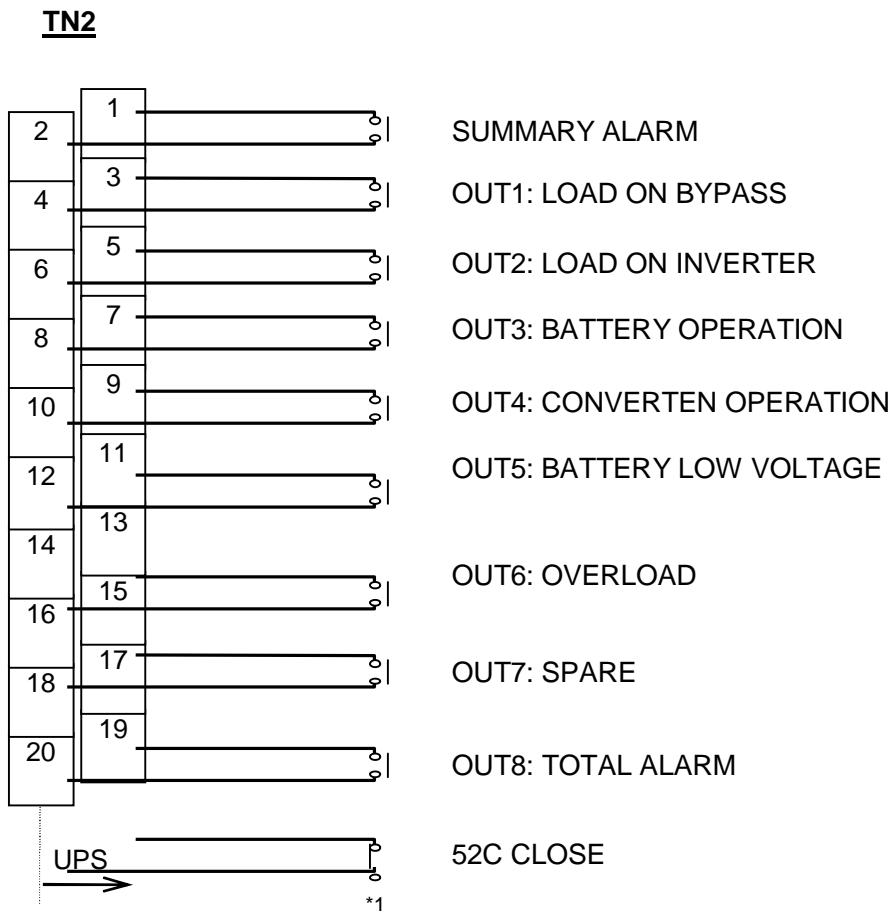
2) SILENCE ALARM

This icon will appear when a failure occurs. The audible alarm (announcing the failure) can be silenced by pressing this icon.

2.4 EXTERNAL SIGNAL TERMINAL BLOCK

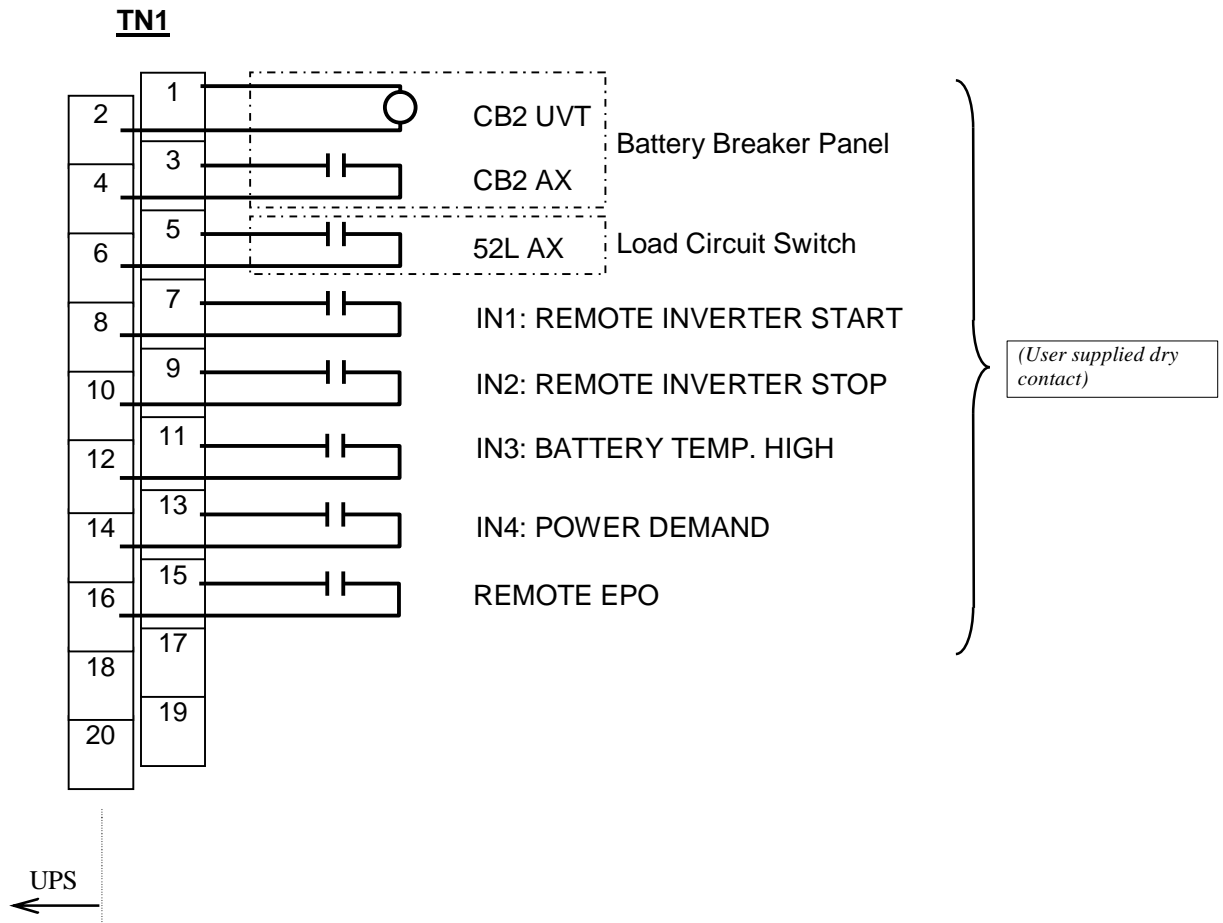
The UPS is equipped with a series of input/output terminals for external annunciation of alarms and for remote access of certain UPS functions. The layout of terminals is shown in Figure 2.10 with a functional description of the input/output port presented. OUT1 to OUT8 are user programmable, but are factory default set being also shown in Figure 2.10. Adding same external I/F PCB “IOAU-09”, doubling signal outputs is applicable for OUT1 to OUT8.

FIGURE 2.10-a External Signal Terminal Block (NEC Class2)



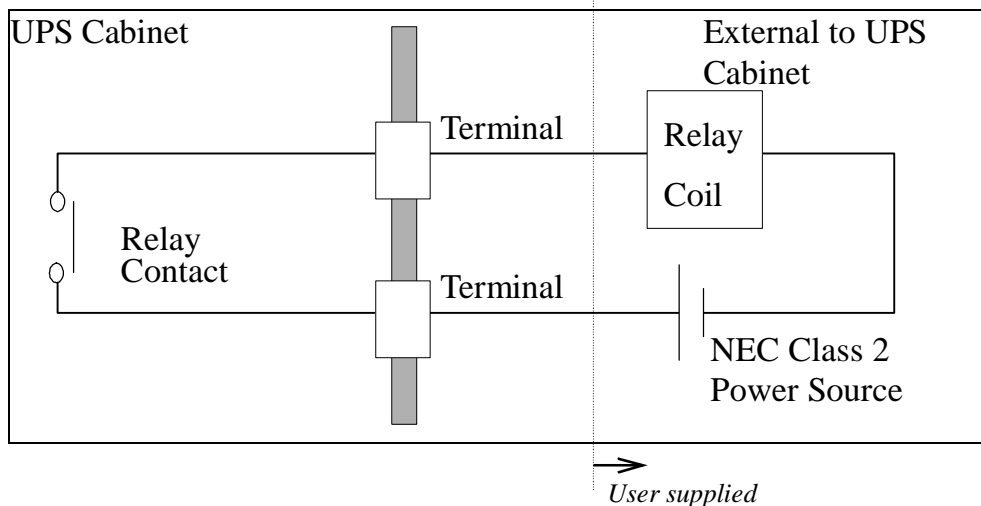
*1 Relay contactor (52C close): Normal Closed

FIGURE 2.10-b External Signal Terminal Block (NEC Class2)



A) Output Contacts (for external alarm annunciation)

Output contacts consist of form " A " dry type contacts. Rated capacity of all output contacts is NEC Class2 (30Vdc/1Adc). All dry contacts should be operated at their rated values or lower. Figure 2.11 illustrates a typical installation. The external relay can also be a lamp, LED, computer, etc.

FIGURE 2.11 Control Wiring for External Contacts

Details of output alarm contacts : TN1
Terminals 1 to 2 "Summary Alarm" contact

Activated when a major fault has occurred with the system.

Terminals 3 to 4 "Load on Bypass" contact (OUT1)

Activated when the power is supplied from the static bypass input.

Terminals 5 to 6 "Load on Inverter" contact (OUT2)

Activated when the power is supplied by the inverter.

Terminals 7 to 8 "Battery Operation" contact (OUT3)

Activated when the battery is operating following an AC power failure.

Terminals 9 to 10 "Converter Operation" contact (OUT4)

Activated when the converter is operating.

Terminals 11 to 12 "Battery Low Voltage" contact (OUT5)

Activated when the battery voltage drops below discharge end voltage level during inverter operation (i.e. During AC fail condition).

Terminals 13 to 14 "Overload" contact (OUT6)

Activated when an overload has occurred to the system.

Terminals 15 to 16 "Total Alarm" contact (OUT7)

Activated during major fault, minor fault and alarm events.

Terminals 17 to 18 "Spare" contact (OUT8)
Terminals 19 to 20 "52C Close" contact (OUT9)

Activated when the inverter output contactor 52C has closed.



NOTE: *The UPS is equipped with a selectable output contact feature. The above alarms are the default settings. Contact MITSUBISHI ELECTRIC POWER PRODUCTS, INC for setup information.*

B) Input Contacts (for remote access of UPS)

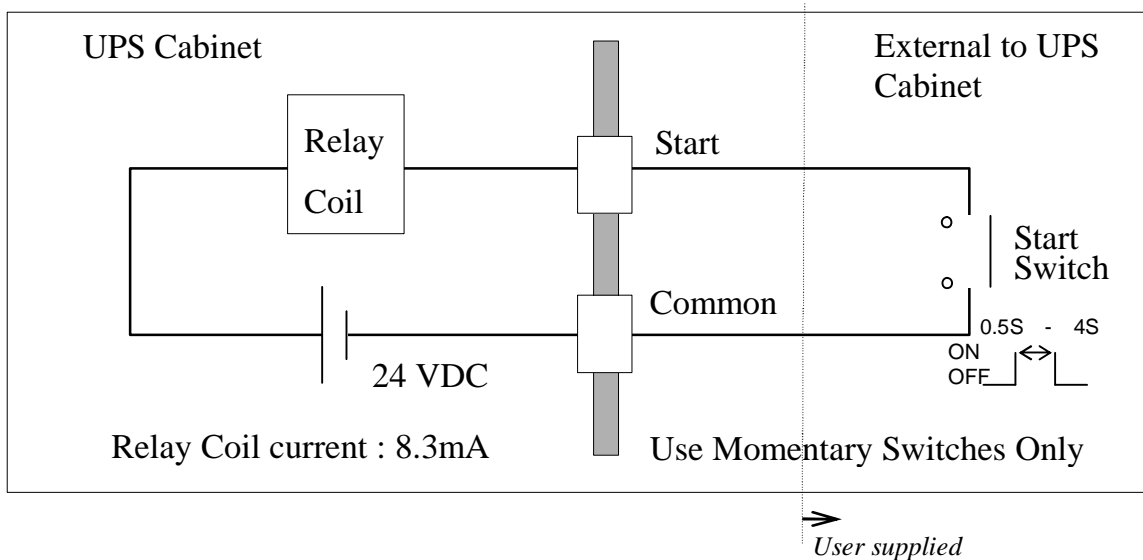
External contacts are provided by the user of the UPS system. Terminal voltage at the UPS is 24Vdc. Provide external dry contact accordingly.



CAUTION: *Do not apply voltages to remote access input terminals. Damage to UPS may result.*

Refer to Figure 2.12 for a typical wiring configuration. Although this figure applies to the remote start/stop terminals, the same wiring arrangement is used for emergency stop; power demand; and battery temperature high.

FIGURE 2.12 Remote "Start" Contact Connections



Details of input contacts for remote access : TN2**Terminals 7 to 8 Remote "Inverter Start" input terminal (IN1)**

Used to start inverter from a remote location. UPS must be programmed for remote operation. Refer to Operations Menu for procedure.

Terminals 9 to 10 Remote "Inverter Stop" input terminal (IN2)

Used to stop inverter from a remote location. UPS must be programmed for remote operation. Refer to Operations Menu for procedure.

Terminals 11 to 12 "Battery Temp. High" contact input (IN3)

Input fed by a thermocouple that monitors battery temperature. The converter float voltage level is reduced for battery over-temperature conditions. External thermocouple is user supplied

Terminals 13 to 14 "Power Demand" Command contact input (IN4)

This contact is used to control the input power. Power demand is turned ON when the contact is closed, and power demand is turned OFF when the contact is open.

Terminals 15 to 16 "Remote EPO" contact input

Used to perform a remote UPS Emergency Power Off (EPO).

The load will be dropped.



NOTE: *The UPS is equipped with a selectable input contact item.*

The above items are the default settings. MITSUBISHI ELECTRIC POWER PRODUCTS, INC for setup information.



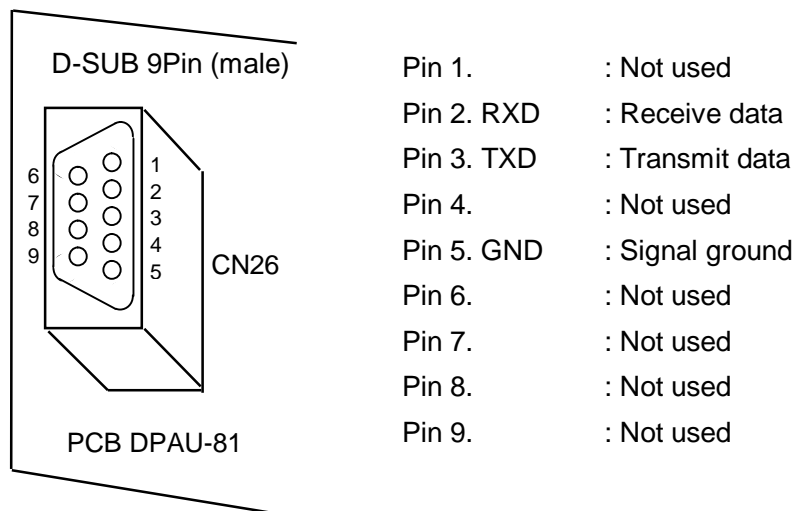
CAUTION : *In all cases, a switch having a protective cover is recommended in order to reduce the possibility of accidental operation.*

2.5 EXTERNAL COMMUNICATION CONNECTOR

This is an RS232C port for "DiamondLink"* monitoring software.

The layout of connector is shown in Figure 2.13.

FIGURE 2.13 External communication connector (NEC Class2)



** Consult MITSUBISHI ELECTRIC POWER PRODUCTS, INC for details on "DiamondLink" monitoring software and its capabilities.*

3.0 INSTALLATION AND OPERATION

3.1 TRANSPORTATION AND INSTALLATION

TABLE 3.1 How to transport and install the system

Transportation	Installation
Transport unit with forklift. Carry with overhead crane using 4xM12 screw-eyebolts. (Not provided)	Using the pre-drilled four holes in the UPS channel base, anchor the unit using appropriate hardware. (Not provided)



CAUTION : *Do not transport in a horizontal position. Cabinets must be maintained upright within +/- 15° of the vertical during handling.*

3.2 INSTALLATION PROCEDURE

A) Note the load tolerance of the floor

Refer to Table 3.2 for list of UPS weights.

TABLE 3.2 List of UPS weights

UPS Capacity (kVA)	80	100	150	225
Weight (lb.)	880	880	1160	1230

B) Minimum clearance required for ventilation

Right side 25 mm (1 inch) (not required when sidecars are used)

Left side 25 mm (1 inch) (not required when sidecars are used)

Back side 0.0 mm (0 inch)

Top side 500 mm (20 inches) (for air flow)

C) Space requirement for routine maintenance

Allow for the following space at the time of installation.

Front 1000 mm (40 inches)

Sides 0.0 mm (0 inch)

Back side 0.0 mm (0 inch)

Top side 500 mm (20 inches)

D) External Battery Supply

Please refer to the following when installing and maintaining batteries:



1. The customer shall refer to the battery manufacturer's installation manual for battery installation and maintenance instructions.
2. The maximum permitted fault current from the remote battery supply, and the DC voltage rating of the battery supply over-current protective device are shown in Table 3.3.

TABLE 3.3 Maximum Permitted Fault Current

UPS Capacity (kVA)	DC Voltage Rating (V)	Maximum Fault Current Permitted (A)
80	480	25,000
100	480	25,000
150	480	25,000
225	480	25,000

3.3 PROCEDURE FOR CABLE CONNECTIONS *

1. Confirm the capacity of the UPS being installed. Identify the input/output power terminal blocks as shown in the appropriate Figures 3.1 through 3.3.
2. Connect the internal control wire and power wire.
 - (1) Control wire Inter-connect
 1. CB2 UVT to terminal TN1-1, 2 of external I/F PCB IOAU-09.
 2. CB2 ON Auxiliary to terminal TN1- 3, 4 of external I/F PCB IOAU-09.
 - (2) Power wire (AC input, Bypass input, AC output) Inter-connect
 - a.) From user's distribution panel
 1. X1 (A-phase) to A bus bar in UPS
 2. X2 (B-phase) to B bus bar in UPS
 3. X3 (C-phase) to C bus bar in UPS
 - b.) DC Input to UPS
 1. Positive cable to BP bus bar in UPS
 2. Negative cable to BN bus bar in UPS



CAUTION : *After the completion of the input power cables connection:*

With a phase rotation meter, check that the phase rotation of the AC Input power terminals A, B and C as well as the Bypass Input power terminals A40, B40 and C40 are correct. The proper phase rotation is clockwise A → B → C.

3. Connect the grounding conductor from the input service entrance to the UPS Ground Bar (E).
4. Two (2) sources feeding the UPS:
 - (1) Connect the AC input power cables from the input service entrance to the AC input power terminals, identified as A, B, C in Figures 3.1 to 3.3. Input cables must be sized for an ampere rating larger than the maximum input drawn by the converter. (Refer to equipment nameplate for current ratings.) Confirm that an external bypass input circuit breaker (MCCB) is installed (refer to WARNING 4, page 1-4). Connect the bypass input power cables from the input service entrance to the bypass input power terminals, identified as A40, B40 and C40 in Figures 3.1 to 3.3. Bypass input cables must be sized for an ampere rating larger than the maximum output current capacity of the UPS. Refer to Table 3.4 for recommended cable sizes.
 - (2) Connect the external signal terminal block as desired. Refer to section 2.4 and Figure 2.10 for functional description. 2mm², or less, shielded conductor is recommended.
5. One (1) source feeding the UPS:
 - (1) Confirm that an external input circuit breaker sized to protect both the AC input and the bypass line is installed. (Refer to equipment nameplate for current ratings.) Connect the bypass input power cables from the input service entrance to the bypass input power terminals, identified as A40, B40 and C40 in Figures 3.1 to 3.3. Input cables must be sized for an ampere rating larger than the maximum current capacity of the UPS. Refer to Table 3.4 for recommended cable sizes.
 - (2) Using adequately sized conductors and referring to the appropriate figure identified in Figures 3.1 to 3.3, connect jumper bypass terminals A40, B40, C40 to AC input power terminals A, B, C as identified in Figures 3.1 to 3.3.

- (3) Connect the external signal terminal block as desired. Refer to section 2.4 and Figure 2.10 for functional description. 2mm², or less, shielded conductor is recommended.

CAUTION : 1. *Confirm that all UPS internal contactors (breakers) "CB1", "CB2", and "CB3" are open before energizing UPS.*



2. *UPS power terminals are supplied with stud type fittings.*

It is recommended that compression lugs be used to fasten all input/output power cables.

6. Procedure for Cable Connections for Parallel Operation System
- (1) Confirm the number of units to be connected in parallel. Identify the input/output power terminal blocks and control wire connections for parallel operation systems as shown in the appropriate Figures 3.4 and 3.5.
- (2) Connect the external control wire and power wire.
- a.) Control wire connection
- Parallel configuration wiring (Refer to Figure 3.4 and 3.5.)
- 52L control signal from Critical Load Cabinet (CLC) to UPS-n IOAU-09 (TN1- 5 , 6).
 - Parallel control signal for CN94 as shown in Fig. 3.5.
 - Parallel control signal for CN96 and CN95 as shown in Fig. 3.5.
- b.) Power wire connection
- From UPS AC Output Terminals to Critical Load Cabinet (CLC) (Refer to Figure 3.4 and 3.5.)

TABLE 3.4 Recommended Cable Sizes

kVA Capacity	Input Voltage	Output Voltage	Input Side		Output Side		Bypass Side		DC Input Side	
			Cable Size	Torque in. lbs	Cable Size	Torque in. lbs	Cable Size	Torque in. lbs	Cable Size	Torque in. lbs
80kVA	480V	480V	1/0 AWG	100 - 135 in. lbs	1/0 AWG	100 - 135 in. lbs	1/0 AWG	100 - 135 in. lbs	2/0 AWG	100 - 135 in. lbs
100kVA	480V	480V	2/0 AWG	100 - 135 in. lbs	2/0 AWG	100 - 135 in. lbs	2/0 AWG	100 - 135 in. lbs	3/0 AWG	100 - 135 in. lbs
150kVA	480V	480V	1 AWG by 2	100 - 135 in. lbs	1 AWG by 2	100 - 135 in. lbs	1 AWG by 2	100 - 135 in. lbs	2/0 AWG by 2	100 - 135 in. lbs
225kVA	480V	480V	3/0 AWG by 2	100 - 135 in. lbs	3/0 AWG by 2	100 - 135 in. lbs	3/0 AWG by 2	100 - 135 in. lbs	250MCM by 2	100 - 135 in. lbs

*1 - The cables must be selected to be equal to the sizes listed in the table.

*2 - Voltage drop across power cables not to exceed 2% of nominal source voltage.

*3 - Allowable ampere-capacities based on 75 degree C. insulation at ambient temperature of 40 degree C.

Note: Copper conductors assumed.

TABLE 3.5 Crimp Type Compression Lug

WIRE SIZE (CODE)	WIRE STRAND CLASS	RECOMMENDATION		CRIMP TOOL REQUIRED BURNDY TYPE Y35 OR Y46	
		VENDOR	CAT. NO.	COLOR KEY	DIE INDEX
1	B	BURNDY	YA1C	GREEN	11 / 375
	I	ILSCO	CRA-1L	GREEN	11 / 375
		BURNDY	YA25-LB	---	1019
1/0	B	BURNDY	YA25	PINK	12 / 348
	I	ILSCO	CRA-1/OL	PINK	12 / 348
		BURNDY	YA25-LB	---	1020
2/0	B	BURNDY	YA26	BLACK	13
	I	ILSCO	CRA-2/OL	BLACK	13
		BURNDY	YA27-LB	---	1021
3/0	B	BURNDY	YA27	ORANGE	14 / 101
	I	ILSCO	CRB-3/OL	ORANGE	14 / 101
		BURNDY	YA28-LB	---	1022
4/0	B	BURNDY	YA28	PURPLE	15
	I	ILSCO	CRB-4/OL	PURPLE	15
		BURNDY	YA29-LB	---	1023
250 MCM	B	BURNDY	YA29	YELLOW	16
	I	ILSCO	CRA-250L	YELLOW	16
		BURNDY	YA30-LB	---	1024
300 MCM	B	BURNDY	YA30	WHITE	17 / 298
	I	ILSCO	CRA-300L	WHITE	17 / 298
		BURNDY	YA32-LB	---	1026
350 MCM	B	BURNDY	YA31	RED	18 / 324
	I	ILSCO	CRA-350L	RED	18 / 324
		BURNDY	YA34-LB	---	1027
400 MCM	B	BURNDY	YA32	BLUE	19 / 470
	I	ILSCO	CRA-400L	BLUE	19 / 470
		BURNDY	YA36-LB	---	1027
500 MCM	B	BURNDY	YA34	BROWN	20 / 299
	I	ILSCO	CRA-500L	BROWN	20 / 299
		BURNDY	YA38-LB	---	1029

NOTE: When using crimp type lugs, the lugs should be crimped to the specifications given in the manufacturer's instructions for both crimp tool and lug.

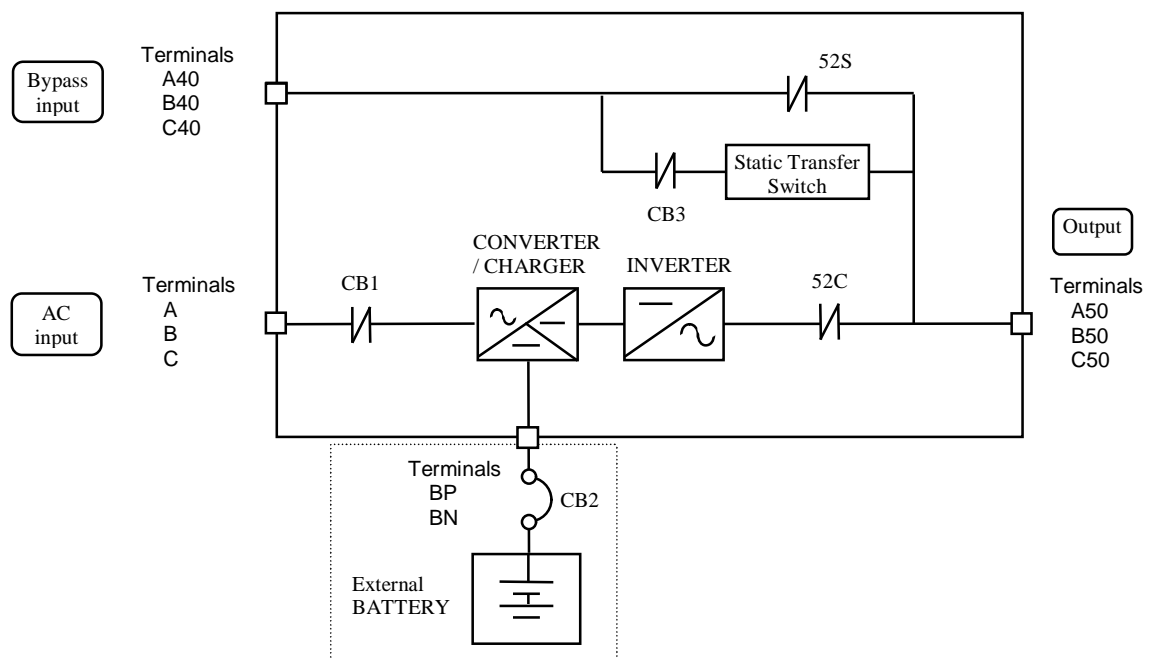
FIGURE 3.1 UPS Terminal Designation


FIGURE 3.2 Diagram of input/output bus bars and terminal blocks

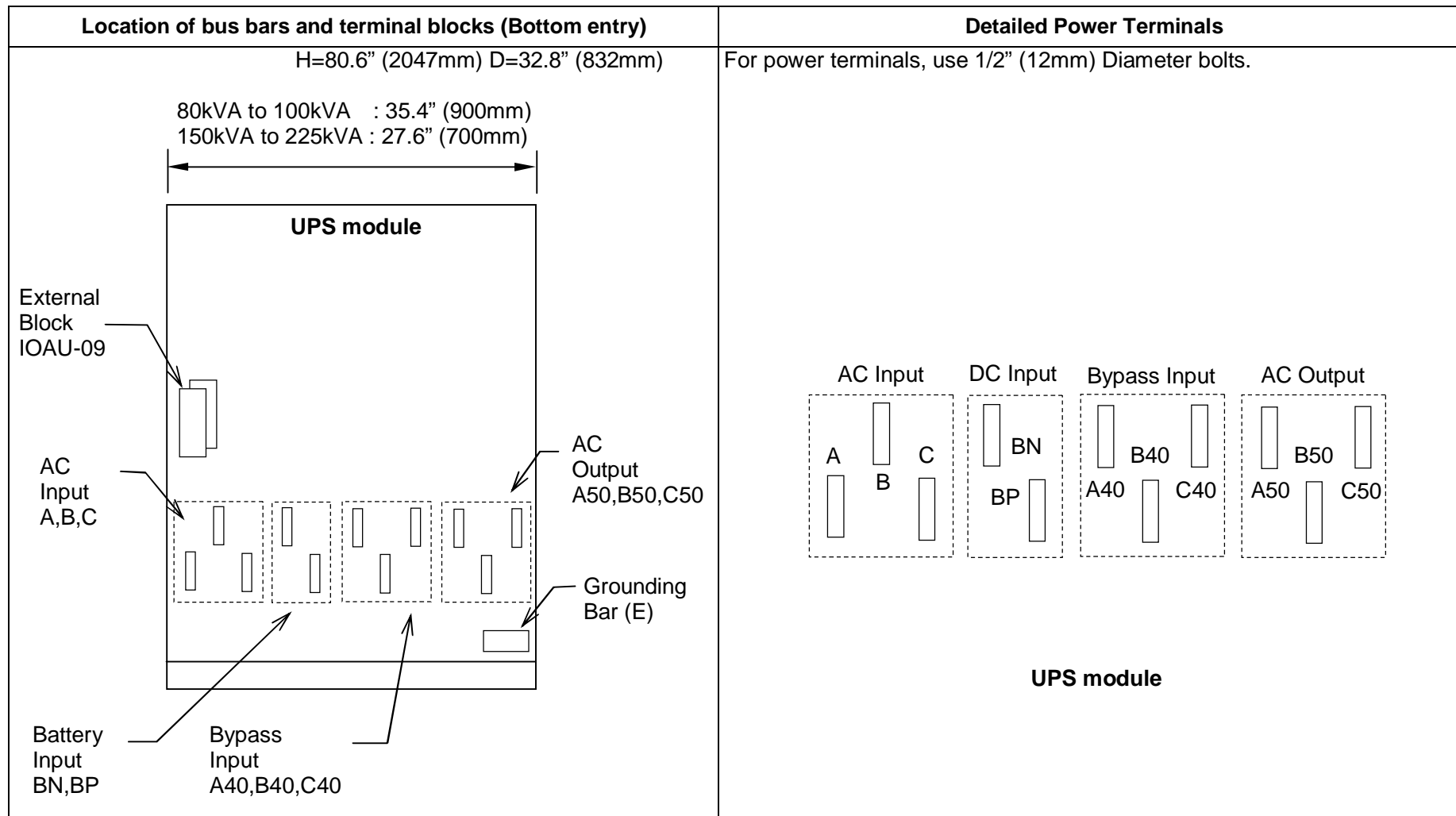


FIGURE 3.3 Diagram of Power Wire & Control Wire Inter-Connect between UPS and Battery

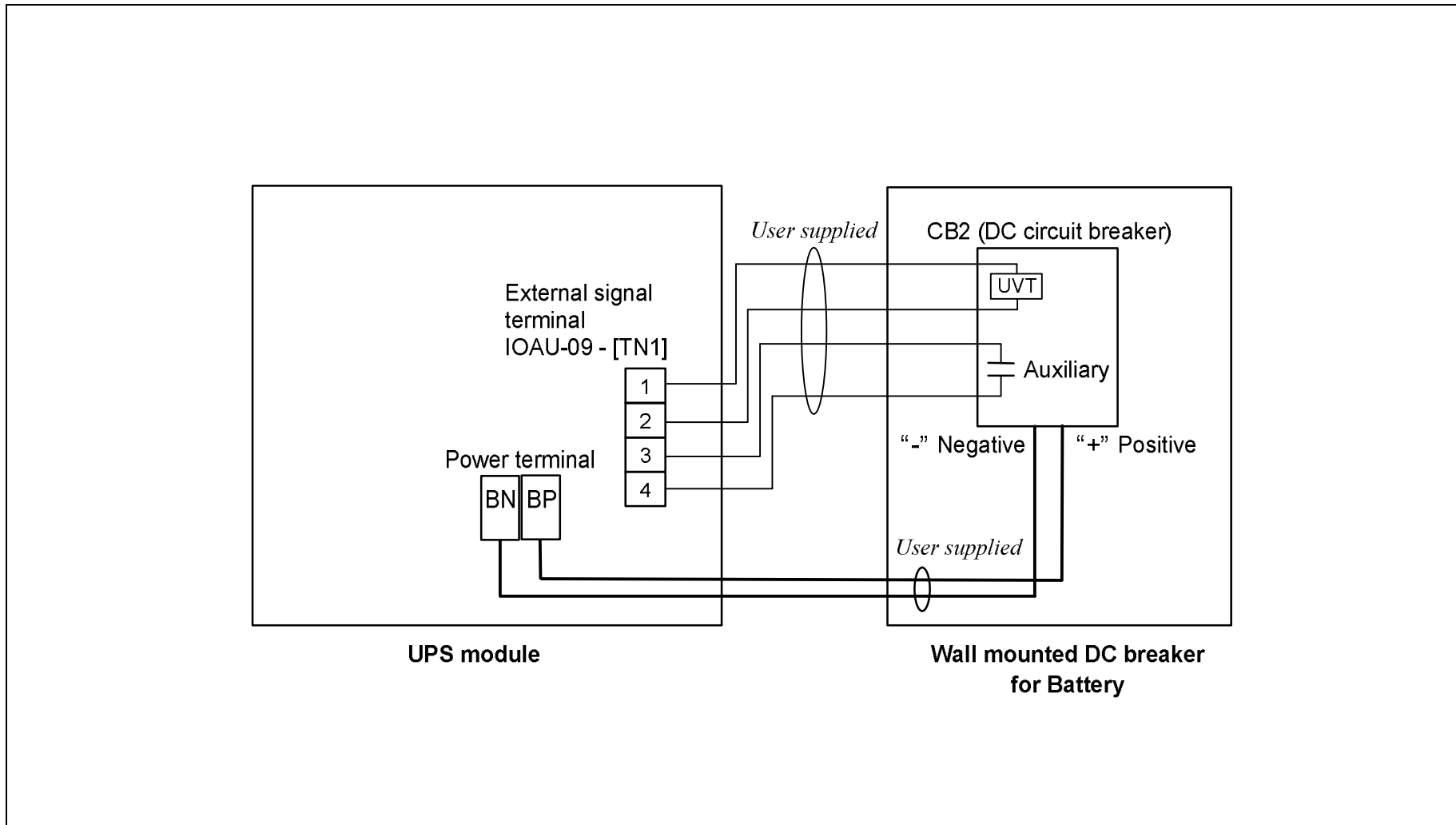


FIGURE 3.4 Diagram of Power Wire Connect (Parallel Operation system connection)

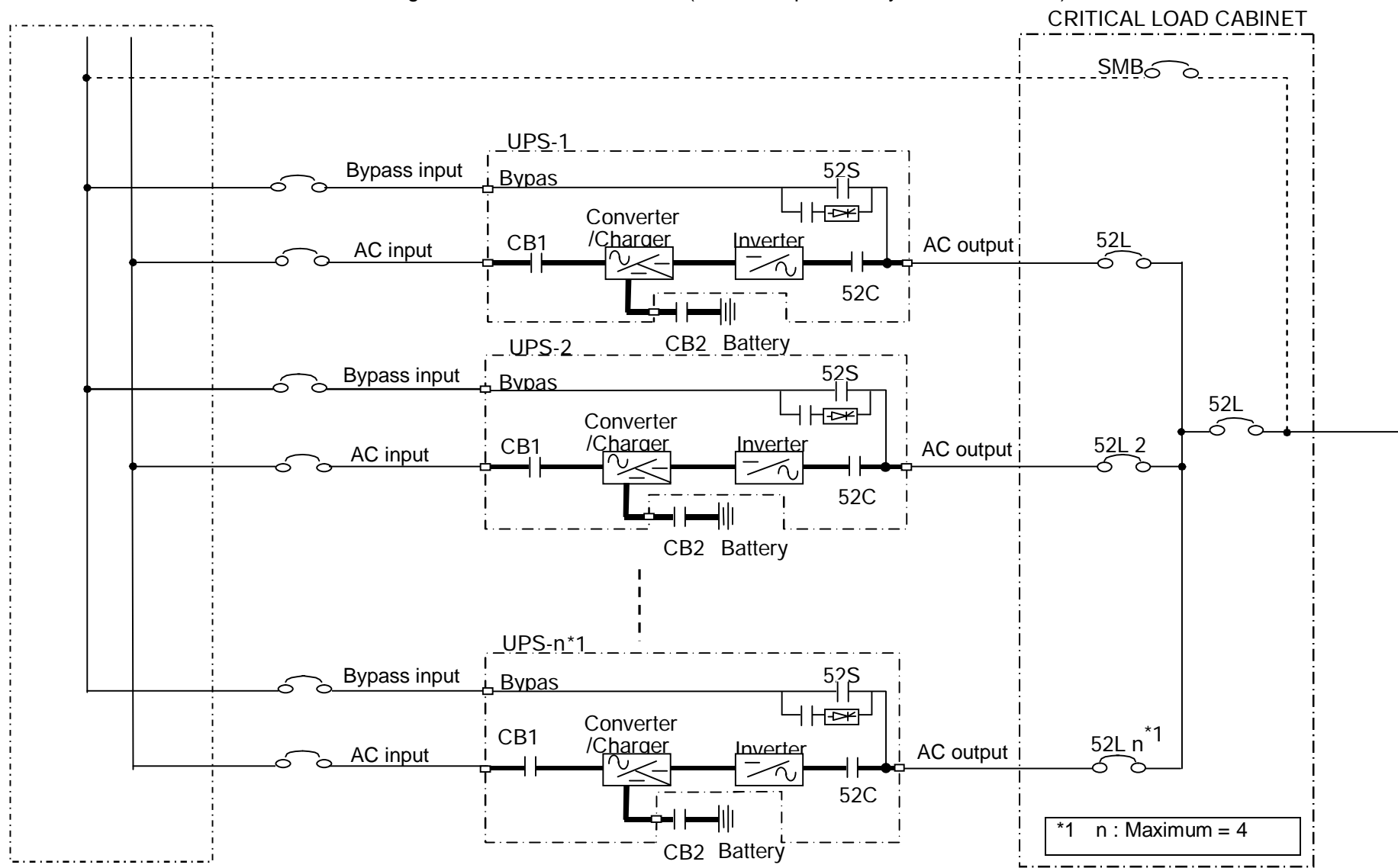
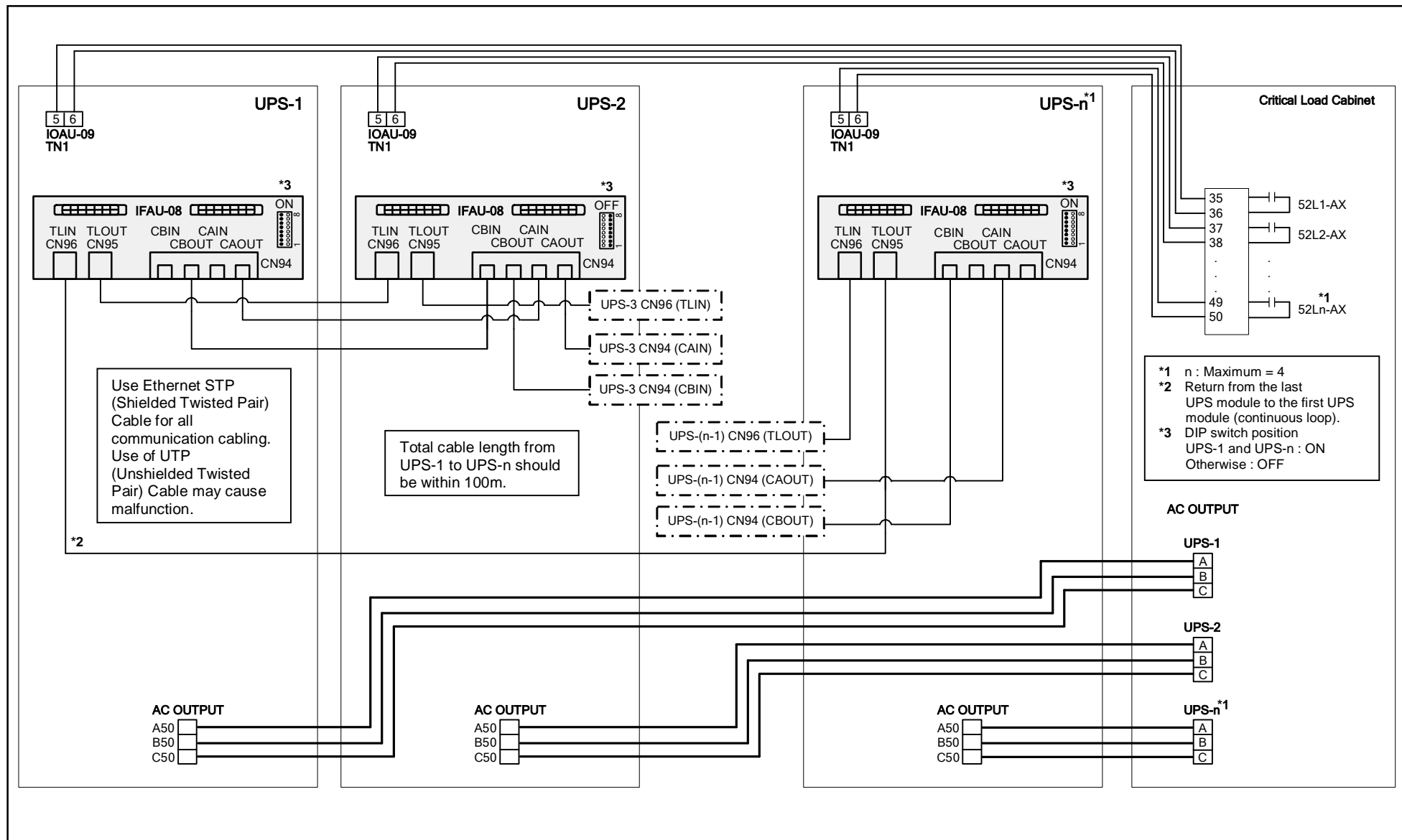


FIGURE 3.5 Diagram of Power Wire & Control Wire Connect (Parallel Operation system connection)



3.4 OPERATING PROCEDURES

For Parallel Operation system, refer to section “D) MMS Start-up Procedure”.
(Parallel Operation system is herein after MMS [Multi Module System])

A) Start-up Procedure



CAUTION : *Before the UPS startup, the internal Bypass line starts to supply the unconditioned bypass input power to the critical load if the External input (or Bypass) Circuit Breaker is closed. Be extremely careful with closing the External input (or Bypass) Circuit Breaker.*

- a.) Verify that the External Bypass Input Circuit Breaker for each unit is closed.
(user supplied)
- b.) Verify that Battery Disconnect Circuit Breaker (CB2) is opened or in tripping position.
- c.) If a dual source is feeding the UPS, close the External AC Input Circuit Breaker manually (user supplied).
- d.) The LCD panel boots up automatically, and the screen will show that the Load is powered by bypass line.
- e.) On the LCD panel, select “OPERATION” tab, and then press the “STARTUP GUIDANCE” button to proceed with UPS start-up. (Refer to Figure 2.3)
- f.) Follow the “STARTUP GUIDANCE” accordingly until the completion of the inverter startup.



Note: *When "REMOTE OPERATION MODE" is displayed on the LCD panel, the inverter start operation can only be performed remotely. If local inverter start operation is required (at the UPS), select "LOCAL ONLY" or "REMOTE & LOCAL" in the OPERATION MENU.*

B) Shut-down Procedure

If a total UPS shutdown is required, verify that the critical load is OFF.

- a.) Press the "START/STOP" icon from the Main Menu or the Operation Menu on the LCD.
- b.) On the LCD panel, press "START/STOP" icon, and then select "SHUTDOWN GUIDANCE" icon. (Refer to Figure 2.3)
- c.) Follow the "SHUTDOWN GUIDANCE" accordingly until Inverter stops. However UPS will simultaneously transfer the power feeding from the Inverter supply to the Bypass line supply.
- d.) In general, only the Inverter will be stopped and the Converter will remain energized to charge the batteries.



Note: When "REMOTE OPERATION MODE" is displayed on the LCD panel, the inverter start operation can only be performed remotely. If local inverter stop operation is required (at the UPS), select "LOCAL ONLY" or "REMOTE & LOCAL" in the OPERATION MENU.

- e.) If stopping both the Inverter and Converter is required, open the Battery Disconnect circuit breaker (CB2) manually in accordance with guidance.

WARNING : Verify the load is OFF if the next step is to be performed .



NOTE : Power to the critical load is supplied through the bypass line. Power to the critical load will be lost after execution of the next step. The load will drop.

- f.) If a dual source is feeding the UPS, open the External AC Input Circuit Breaker (user supplied) manually.
- g.) If turning off all power to the critical load is desired, open the External Bypass Input Circuit Breaker (user supplied) manually.



CAUTION : In bypass mode, all UPS power terminals are still live. Lethal voltages are present. De-energize all external sources of AC and DC power. Before removing the covers, wait 5 minutes after de-energizing. Check no-voltage before handling UPS. Be careful for the devices even when the UPS has been de-energized, still internal devices may be hot.

C) Bypass Operation Procedure

** Transfer from Inverter to Bypass

1. Check for "SYNC" on the LCD.
2. Press the "START/STOP" icon on the LCD.
3. Follow the "SHUTDOWN GUIDANCE" and Press the "STOP" icon on the LCD.

** Transfer from bypass to inverter.

UPS

1. Press the "START/STOP" icon on the LCD.
2. Follow the "STARTUP GUIDANCE" and Press the "START" icon on the LCD..



Note: When "*REMOTE OPERATION MODE*" is displayed on the LCD panel, the inverter start operation can only be performed remotely. If local inverter start or stop operation is required (at the UPS), select "*LOCAL ONLY*" or "*REMOTE & LOCAL*" in the *OPERATION MENU*.

D) MMS Start-up Procedure

External Circuit Check

1. Verify that Critical Load Cabinet (CLC) Circuit Breaker SMB is closed.
2. Verify that CLC System Output Circuit Breaker 52L is open.
3. Verify that CLC UPS Circuit Breakers 52L1, 52L2...and 52Ln are closed.

Start-up from UPS-1 to UPS-n

1. Start-up each UPS in accordance with "A) Start-up Procedure". Each UPS will start Inverter Operation in synchronization with the bypass input.

Transfer from Maintenance Bypass to MMS Bypass Operation

1. Closed the CLC System Output Circuit Breaker 52L.
2. Open the CLC Circuit Breaker SMB.

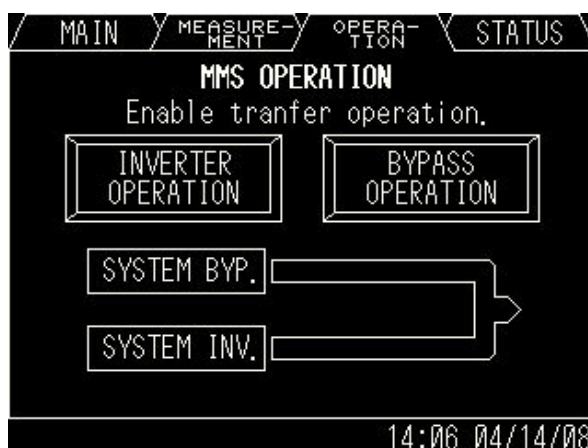


Note: When "REMOTE OPERATION MODE" is displayed on the LCD panel, the inverter start operation can only be performed remotely. If local inverter start operation is required (at the UPS), select "LOCAL ONLY" or "REMOTE & LOCAL" in the OPERATION MENU.

Transfer from UPS MMS Bypass Operation To UPS MMS Inverter Operation

1. Transfer MMS Bypass Operation to MMS Inverter Operation from Operation Menu on any UPS LCD as shown in Fig. 3.6.

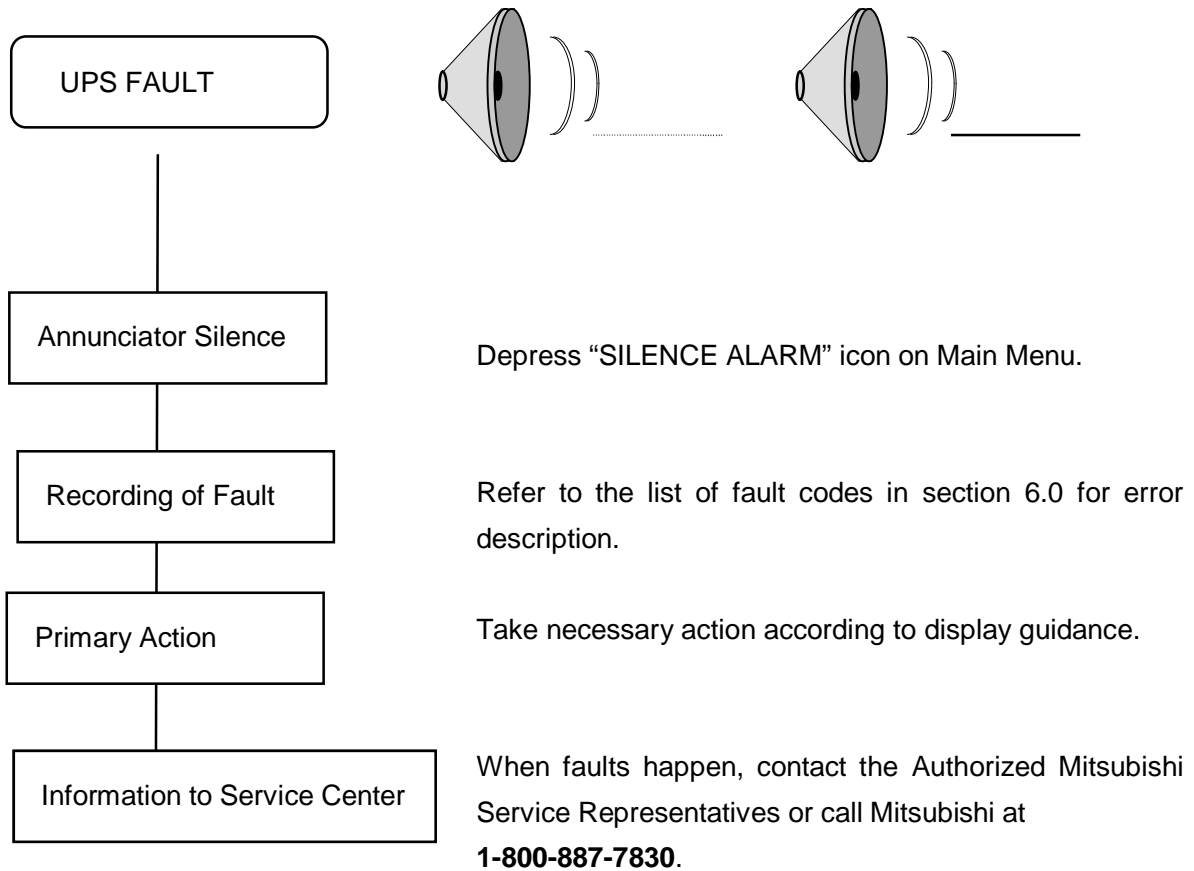
FIGURE 3.6 LCD Screen (MMS Operation)



Transfer from UPS MMS Inverter Operation To UPS MMS Bypass Operation

1. Transfer MMS Inverter Operation to MMS Bypass Operation from Operation Menu on any UPS LCD as shown in Fig. 3.6.

4.0 RESPONSE TO UPS FAILURE



Note

The error code indicated on the LCD display panel when an UPS alarms is very important. In order to reduce repair time, please include this information, along with the operation and load status for all correspondence to Mitsubishi field service group.

5.0 PARTS REPLACEMENT

Contact Mitsubishi Electric Power Products, Inc. or its authorized service representatives on all issues regarding the replacement of parts.

A) Battery

Battery lifetime may vary according to the frequency of use and the average ambient operating temperature. The end of battery life is defined as the state of charge resulting in an ampere-hour capacity less than, or equal to, 80% of nominal capacity.

Replace battery if its capacity is within this percentage.

B) UPS Component Parts

UPS components have a defined life expectancy (Fan, Capacitors, Filters, etc).

Contact Mitsubishi Electric Power Products, Inc. or its authorized service representatives for a complete parts replacement schedule. Recommended replacement time interval varies with operating environment.

Contact Mitsubishi Electric Power Products, Inc. or its authorized service representatives for application specific recommendations.



NOTE : *Any parts replacements (including modification) without authorized by Mitsubishi could result in personal injuries, death or destruction of the UPS.*

6.0 FAULT CODES

This section covers fault codes, their description and required action.

At time of error :

- A) Verify and record the occurrence of the alarm. Note details of alarm message displayed on the LCD display panel.

Contact Mitsubishi Electric Power Products, Inc. at 1-800-887-7830.

- B) If a circuit breaker (MCCB) has tripped, depress the toggle to reset the breaker before closing it again.

Failure Code List
Table 6.1 Fault Code

Note 3 Code indication	Status message	Meaning	Guidance	Buzzer	Note 1 External relay contact	Note 2 Failure lamp
UA801	AC INPUT VOLTAGE OUT OF RANGE	Input line voltage is out of the specified range.	CHECK INPUT POWER SOURCE	Intermittent sound	Alarm AC input abnormal	-
UA802	AC INPUT FREQUENCY OUT OF RANGE	Input line frequency is out of the specified range.	CHECK INPUT POWER SOURCE	Intermittent sound	Alarm AC input abnormal	-
UA803	AC INPUT PHASE ROTATION ERROR	Input line power conductors are not wired in a proper phase sequence.	CHECK INPUT POWER SOURCE	Intermittent sound	Alarm AC input abnormal	-
UA804	CONVERTER OPE. PROHIBITION	The converter interlock is active.	-	Intermittent sound	Alarm	-
UA805	INVERTER OVERLOAD	The output load current has exceeded 105% of the rated current.	WARNING : DECREASE LOAD	Intermittent sound	Alarm Overload	-
UA806	INVERTER OVERLOAD	The output load current has exceeded 110% of the rated current.	WARNING : DECREASE LOAD	Intermittent sound	Alarm Overload	-
UA807	INVERTER OVERLOAD	The output load current has exceeded 125% of the rated current.	WARNING : DECREASE LOAD	Intermittent sound	Alarm Overload	-
UA808	INVERTER OVERLOAD	The output load current has exceeded 150% of the rated current.	WARNING : DECREASE LOAD	Intermittent sound	Alarm Overload	-
UA810	INVERTER OVERLOAD	Short time over-current has been detected during the inverter operation.	WARNING : DECREASE LOAD	Intermittent sound	Alarm Overload	-
UA812	BYPASS VOLTAGE OUT OF RANGE	Bypass line voltage is out of the specified range.	CHECK BYPASS INPUT	Intermittent sound	Alarm Bypass input abnormal	-
UA813	BYPASS PHASE ROTATION ERROR	Bypass line power conductors are not wired in a proper phase sequence.	CHECK BYPASS INPUT	Intermittent sound	Alarm Bypass input abnormal	-
UA814	BYPASS FREQUENCY OUT OF RANGE	Bypass line frequency is out of the specified range.	CHECK BYPASS INPUT	Intermittent sound	Alarm Bypass input abnormal	-
UA815	TRANSFER PROHIBITION	Transfer to the bypass is not available due to bypass abnormality.	-	Intermittent sound	Alarm	-
UA817	EMERGENCY STOP ACTIVATED	The emergency stop was activated by the EPO switch or an external contact.	-	-	Alarm	-

Note 3 Code indication	Status message	Meaning	Guidance	Buzzer	Note 1 External relay contact	Note 2 Failure lamp
UA821	TRANSFER PROHIBITION	The UPS could not transfer to the bypass because the inverter output was not synchronized to the bypass.	-	-	Alarm	-
UA822	TRANSFER PROHIBITION	The UPS could not transfer to the bypass because of backup generator operation.	-	-	Alarm	-
UA824	CB2 OPEN	The battery circuit breaker (CB2) is open.	TURN ON CB2	Intermittent sound	Alarm	-
UA827	52C OPE. PROHIBITION	The interlock for the inverter output contactor (52C) is active.	-	Intermittent sound	Alarm	-
UA831	EMERGENCY BYPASS SWITCH ON	Emergency bypass switch has been turned on.	-	Intermittent sound	Alarm	-
UA833	52L OPEN	The load circuit breaker(52L) is turned off.	-	Intermittent sound	Alarm	-
UA834	BATTERY DEPLETED/A C OUT STOPPED	The battery voltage has reached the depleted level.	-	-	Major End-of-Discharge	Lit on
UA835	TRANSFER PROHIBITION	The UPS could not transfer to the bypass because the bypass source has an abnormality.	-	-	Alarm	-
UA860	REMOTE BUTTON ABNORMAL	Remote start or stop signal is being received continuously for a considerable time.	-	Intermittent sound	Alarm	-
UA861	LOCAL BUTTON ABNORMAL	Local start or stop signal is being received continuously for a considerable time.	-	Intermittent sound	Alarm	-
UA870	BALANCER OVERLOAD	The UPS detected an neutral point voltage unbalance.	-	Intermittent sound	Alarm Overload	-
UA890	EXTERNAL ALARM	External Alarm relay turned on.	-	Intermittent sound	Alarm	-
UF001	INPUT CIRCUIT ABNORMAL	Detection of a large variation of the reference error signal.	CALL SERVICE ENGINEER	Continuous sound	Major	Lit on
UF002	CONVERTER OVERCURRENT	Detection of converter overcurrent.	CALL SERVICE ENGINEER	Continuous sound	Major	Lit on
UF003	CONVERTER ABNORMAL	Pre-charging circuit is not working properly.	CALL SERVICE ENGINEER	Continuous sound	Major	Lit on
UF011	CB1 ABNORMAL	Major discrepancy between reference signal and actual state of contactor CB1.	CALL SERVICE ENGINEER	Continuous sound	Major	Lit on
UF052	CB1 ABNORMAL	Minor discrepancy between reference signal and actual state of contactor CB1.	CALL SERVICE ENGINEER	Intermittent sound	Minor	Flicker
UF056	CONVERTER OVERCURRENT	Detection of converter overcurrent.	CALL SERVICE ENGINEER	Intermittent sound	Minor	Flicker
UF059	INPUT CIRCUIT ABNORMAL	Detection of a large variation of the reference error signal.	CALL SERVICE ENGINEER	Intermittent sound	Minor	Flicker
UF102	DC OVERVOLTAGE	DC voltage surpasses the overvoltage level.	CALL SERVICE ENGINEER	Continuous sound	Major	Lit on

UF103	DC UNDERVOLTAGE	DC voltage dropped below the undervoltage level.	CALL SERVICE ENGINEER	Continuous sound	Major	Lit on
UF108	CHOPPER OVERCURRENT	Detection of DC overcurrent.	CALL SERVICE ENGINEER	Continuous sound	Major	Lit on

Note 3 Code indication	Status message	Meaning	Guidance	Buzzer	Note 1 External relay contact	Note 2 Failure lamp
UF109	DC UNBALANCED	Major unbalance of the neutral point voltage.	CALL SERVICE ENGINEER	Continuous sound	Major	Lit on
UF110	ZERO PHASE OVERCURRENT	Detection of converter zero-sequence overcurrent.	CALL SERVICE ENGINEER	Continuous sound	Major	Lit on
UF111	UPS CONTROL CIRCUIT ERROR	Battery current unbalance.	CALL SERVICE ENGINEER	Continuous sound	Major	Lit on
UF112	DC CIRCUIT ABNORMAL	Sudden change of the DC voltage level.	CALL SERVICE ENGINEER	Continuous sound	Major	Lit on
UF119	DC GROUND FAULT	Detection of DC ground fault.	CALL SERVICE ENGINEER	Continuous sound	Major	Lit on
UF128	CONTROL POWER SUPPLY ABNORMAL	Power supply voltage to IGBT driver PCB is below the specified level.	CALL SERVICE ENGINEER	Continuous sound	Major	Lit on
UF151	DC VOLTAGE ABNORMAL	24 hours after input power restoration, batteries does not reach float voltage level.	CALL SERVICE ENGINEER	Intermittent sound	Minor	Flicker
UF152	DC VOLTAGE ABNORMAL	Unable to equalize the voltage of various batteries after 24 hours.	CALL SERVICE ENGINEER	Intermittent sound	Minor	Flicker
UF154	CB2 ABNORMAL	During UVT, status signal from CB2 is ON.	CALL SERVICE ENGINEER	Intermittent sound	Minor	Flicker
UF156	CHG.STOPPED(BATTERY OVERTEMP.)	UF157 failure persisted for over 2 hours.	CHECK BATTERY	Intermittent sound	Minor Battery abnormal	Flicker
UF157	BATTERY OVERTEMPERATURE	Detection of overtemperature at the batteries.	CHECK BATTERY	Intermittent sound	Minor Battery abnormal	Flicker
UF158	BATTERY LIQUID LOW	Low level of battery electrolyte solution.	CHECK BATTERY	Intermittent sound	Minor Battery abnormal	Flicker
UF159	DC GROUND FAULT	Detection of DC ground fault.	CALL SERVICE ENGINEER	Intermittent sound	Minor	Flicker
UF160	UPS CONTROL CIRCUIT ERROR	Abnormal behavior of DC current sensor.	CALL SERVICE ENGINEER	Intermittent sound	Minor	Flicker
UF161	CHG.STOPPED(DC VOLT. ABNORMAL)	UF151 failure is running for over 24 hours.	CALL SERVICE ENGINEER	Intermittent sound	Minor	Flicker
UF162	BATTERY ABNORMAL	Failure detection based on battery self-check.	CALL SERVICE ENGINEER	Intermittent sound	Minor	Flicker

UF163	BATTERY VOLTAGE ABNORMAL	Battery voltage is abnormality.	CALL SERVICE ENGINEER	Intermittent sound	Minor	Flicker
UF170	VDB SENSOR ABNORMAL	Detection of a large variation of the difference between control-only and protection-only battery voltage.	CALL SERVICE ENGINEER	Intermittent sound	Minor	Flicker
UF201	INVERTER OVERVOLTAGE	Detection of output overvoltage.	CALL SERVICE ENGINEER	Continuous sound	Major	Lit on

Note 3 Code indication	Status message	Meaning	Guidance	Buzzer	Note 1 External relay contact	Note 2 Failure lamp
UF202	INVERTER UNDERVOLTAGE	Output voltage dropped.	CALL SERVICE ENGINEER	Continuous sound	Major	Lit on
UF203	INVERTER OVERCURRENT	Detection of inverter overcurrent.	CALL SERVICE ENGINEER	Continuous sound	Major	Lit on
UF204	OUTPUT CIRCUIT ABNORMAL	Detection of a large variation of the reference error signal (current reference and actual current).	CALL SERVICE ENGINEER	Continuous sound	Major	Lit on
UF206	UPS CONTROL CIRCUIT ERROR	Discrepancy between output voltage and external voltage (bypass, common ac bus)	CALL SERVICE ENGINEER	Continuous sound	Major	Lit on
UF207	ZERO PHASE OVERCURRENT	Inverter zero-sequence overcurrent.	CALL SERVICE ENGINEER	Continuous sound	Major	Lit on
UF208	UPS CONTROL CIRCUIT ERROR	Cross current is abnormality.	CALL SERVICE ENGINEER	Continuous sound	Major	Lit on
UF209	52C ABNORMAL	Error to close the contactor 52C.	CALL SERVICE ENGINEER	Continuous sound	Major	Lit on
UF210	52C ABNORMAL	Error to open the contactor 52C.	CALL SERVICE ENGINEER	Continuous sound	Major	Lit on
UF211	52C ABNORMAL	No answer from contactor 52C during inverter operation.	CALL SERVICE ENGINEER	Continuous sound	Major	Lit on
UF213	OVERTEMPERATURE	Heatsinks temperature exceeds thermal settings.	CALL SERVICE ENGINEER	Continuous sound	Major	Lit on
UF214	COOLING FAN ABNORMAL	Thermal relay activated protection.	CALL SERVICE ENGINEER	Continuous sound	Major	Lit on
UF217	INVERTER OVERVOLTAGE	Detection of inverter output phase overvoltage.	CALL SERVICE ENGINEER	Continuous sound	Major	Lit on
UF230	ZERO PHASE OVERCURRENT	Detection of zero-sequence overcurrent.	CALL SERVICE ENGINEER	Continuous sound	Major	Lit on
UF253	UPS CONTROL CIRCUIT ERROR	Discrepancy between output voltage and inverter voltage, or between output voltage and bypass voltage.	CALL SERVICE ENGINEER	Intermittent sound	Minor	Flicker
UF256	OUTPUT VOLTAGE ABNORMAL	Output voltage is out of the specified range.	CALL SERVICE ENGINEER	Intermittent sound	Minor	Flicker
UF257	52C ABNORMAL	Contactor 52C failed to open during load transfer from inverter to bypass.	CALL SERVICE ENGINEER	Intermittent sound	Minor	Flicker

UF258	LOAD ABNORMAL	Load transfer due to overload for over 4 times within 5 minutes.	CALL SERVICE ENGINEER	Intermittent sound	Minor	Flicker
UF259	ANOTHER UPS ABNORMAL	No detection of another UPS voltage signal.	CALL SERVICE ENGINEER	Intermittent sound	Minor	Flicker
UF301	UPS CONTROL CIRCUIT ERROR	AD reference has an abnormal value.	CALL SERVICE ENGINEER	Continuous sound	Major	Lit on
UF302	UPS CONTROL CIRCUIT ERROR	Detection of an external interruption during the software execution.	CALL SERVICE ENGINEER	Continuous sound	Major	Lit on

Note 3 Code indication	Status message	Meaning	Guidance	Buzzer	Note 1 External relay contact	Note 2 Failure lamp
UF303	UPS CONTROL CIRCUIT ERROR	Timer does not reset in the specified period (WDT settings)	CALL SERVICE ENGINEER	Continuous sound	Major	Lit on
UF305	UPS CONTROL CIRCUIT ERROR	Detection of an abnormal clock speed in the DSP or FPGA.	CALL SERVICE ENGINEER	Continuous sound	Major	Lit on
UF306	UPS CONTROL CIRCUIT ERROR	Control power supply voltage are below the specified level.	CALL SERVICE ENGINEER	Continuous sound	Major	Lit on
UF309	INVERTER VOLTAGE ABNORMAL	Inverter voltage is out of the specified range.	CALL SERVICE ENGINEER	Continuous sound	Major	Lit on
UF310	CONTROL POWER SUPPLY ABNORMAL	Backup control power supplies exhibit abnormal condition.	CALL SERVICE ENGINEER	Continuous sound	Major	Lit on
UF320	UPS CONTROL CIRCUIT ERROR	Cable disconnection in the parallel interface board during load supply.	CALL SERVICE ENGINEER	Continuous sound	Major	Lit on
UF323	UPS CONTROL CIRCUIT ERROR	Major communication error during parallel operation.	CALL SERVICE ENGINEER	Continuous sound	Major	Lit on
UF352	CONTROL POWER SUPPLY ABNORMAL	Backup control power supplies exhibit abnormal condition.	CALL SERVICE ENGINEER	Intermittent sound	Minor	Flicker
UF363	UPS CONTROL CIRCUIT ERROR	Synchronization status signal is being received for a considerable time.	CALL SERVICE ENGINEER	Intermittent sound	Minor	Flicker
UF371	UPS CONTROL CIRCUIT ERROR	Minor communication error during parallel operation.	CALL SERVICE ENGINEER	Intermittent sound	Minor	Flicker
UF372	UPS CONTROL CIRCUIT ERROR	Unable to synchronize the inverter output and the bypass voltage.	CALL SERVICE ENGINEER	Intermittent sound	Minor	Flicker
UF374	UPS CONTROL CIRCUIT	Cable disconnection in the parallel interface board.	CALL SERVICE ENGINEER	Intermittent sound	Minor	Flicker

	ERROR					
UF375	UPS CONTROL CIRCUIT ERROR	Unable to achieve synchronization for parallel operation.	CALL SERVICE ENGINEER	Intermittent sound	Minor	Flicker
UF376	UPS CONTROL CIRCUIT ERROR	No control response from another UPS although its detection is possible.	CALL SERVICE ENGINEER	Intermittent sound	Minor	Flicker
UF377	UPS CONTROL CIRCUIT ERROR	Overload detection signal is being received continuously for a considerable time.	CALL SERVICE ENGINEER	Intermittent sound	Minor	Flicker
UF378	UPS CONTROL CIRCUIT ERROR	No answer for sending synchronizing signal.	CALL SERVICE ENGINEER	Intermittent sound	Minor	Flicker
UF379	UPS CONTROL CIRCUIT ERROR	Abnormal clock speed of the parallel control board processor.	CALL SERVICE ENGINEER	Intermittent sound	Minor	Flicker
UF401	52S ABNORMAL	Error to close the contactor 52S.	CALL SERVICE ENGINEER	Continuous sound	Major	Lit on
UF402	52S ABNORMAL	Error to open the contactor 52S.	CALL SERVICE ENGINEER	Continuous sound	Major	Lit on
UF420	52L OPERATION ERROR	Load circuit breaker 52L opened during inverter operation.	CHECK 52L	Continuous sound	Major	Lit on

Note 3 Code indication	Status message	Meaning	Guidance	Buzzer	Note 1 External relay contact	Note 2 Failure lamp
UF451	52S ABNORMAL	Contactor 52S failed during load transfer from inverter to bypass.	CALL SERVICE ENGINEER	Intermittent sound	Minor	Flicker
UF452	CB3 ABNORMAL	Contactor CB3 is not working properly.	CALL SERVICE ENGINEER	Intermittent sound	Minor	Flicker

- (Note 1) 1) "Major" is defined as major failure. Inverter transferred to the static bypass line;
2) "Minor" is defined as a minor failure. UPS continues to operate normally, but cause of alarm must be identified;

(Note 2) Indicates one of two possible LED illumination patterns - continuously on (lit on) or intermittent (flicker).

(Note 3) Code indication means:

UA+++ -----	Alarm
UF+++-----	Failure
U%0++-----	Rectifier circuit failure
U%1++-----	DC circuit failure
U%2++-----	Inverter circuit failure
U%3++-----	Control circuit failure
U%4++-----	Bypass system failure
U%8++-----	Alarm
U%+00 - U%+49 -----	Major failure
U%+50 - U%+99 -----	Minor failure

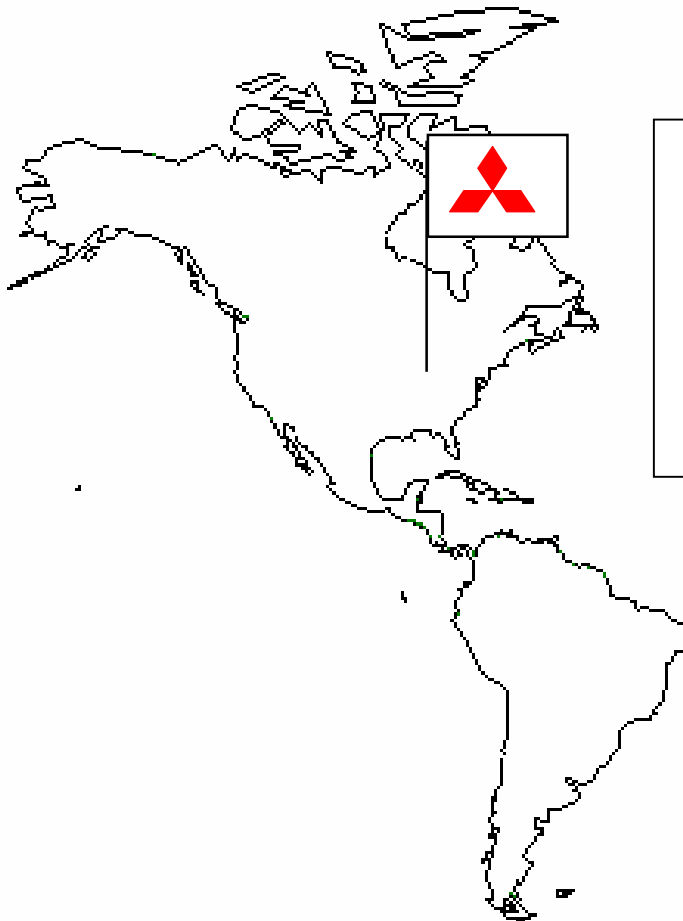
*) "+" denotes any numeral from 0 to 9

*) "%" denotes either "A" or "F"

7.0 WARRANTY & OUT OF WARRANTY SERVICE

The Mitsubishi Electric UPS Division Service Department has many Authorized Service Centers place strategically throughout the US, Canada and Latin America. For both in warranty and out of warranty service, please contact Mitsubishi Electric Power Products, Inc. at (724) 772-2555. To register your UPS for warranty purposes, please complete the warranty registration form and fax it to the Mitsubishi Electric UPS Division Service Department fax line shown on the registration form. (Next page)

For warranty purposes, it is essential that any and all service work that may be required on your Mitsubishi brand UPS equipment is performed by a Mitsubishi Electric Authorized Service Center. The use of non-authorized service providers may void your warranty.



Mitsubishi Electric Power Products, Inc
UPS Division Service Department

530 Keystone Drive,
Warrendale, PA 15086, USA
Phone: (724) 772-2555
Fax: (724) 778-3146


Mitsubishi Electric Power Products, Inc.
 UNINTERRUPTIBLE POWER SUPPLIES

530 Keystone Drive, Warrendale, PA 15086

Phone: (724) 772-2555, Fax: (724) 778-3146

UPS Warranty Registration

 Register UPS for Warranty

 Address Change

To validate the Warranty on your UPS this form must be filled out completely by Customer and returned.

CUSTOMER INFORMATION		
Your Name:	Job Title:	
Company Name:		
Division / Department:		
Address:		
City:	State:	Zip Code:
Country:	Province:	
Business Phone:	Ext:	Fax:
E-Mail: _____ @ _____		Internet Address:
UPS Model #:	Capacity (kVA):	UPS Serial #:
Start-Up Date: / /	Authorized Mitsubishi Service Company (if known):	
Signature: _____		Date: / /

**Which ONE of These Best Describes Your Organization's
Primary Business Classification?**
Number of Employees at This Location is:
 {Energy Producer}
 Utility
 Alternate Energy

 Education/Univ. Service
 {Service}

 1 - 19 100 - 249 1000 or more
 20 - 49 250 - 499
 50 - 99 500 - 999

 {Manufacturing Co.}

 OEM
 Process

 Engineering
 Outsourcing
 Financial/Legal/Insurance

Overall how was Start-Up performed:
 Unsatisfactory Satisfactory Exceeded

 Consumer Goods

 Electronics

 Power Quality Equipment

 {Government}

 Military

 Municipals

 Federal/State/Local

Would you like to receive future product updates and news?
 Yes No

 Commercial Business

 Electrical Contractor

 Healthcare

 Internet

 Communications

 Distributors/Reps

 Other _____

**After Start-Up has been done Fax completed Form to:
(724) 778-3146**